

USEFUL EQUATIONS FOR THE ABIH EXAMINATIONS

This list of equations is offered as assistance in taking the ABIH examinations. No assurance is given that this list is complete or that the use of this list will assure the successful completion of any examination. The variables used are the same as found in the reference source for the equation. No attempt has been made to standardize variables.

VENTILATION

$$Q = VA \quad V_1 A_1 = V_2 A_2 \quad TP = VP + SP \quad SP_1 + VP_1 = SP_2 + VP_2 + h_L \quad V = 4005\sqrt{VP} \quad |SP_h| = VP + h_e$$

$$h_e = \frac{1 - C_e^2}{C_e^2} VP \quad h_e = F_h x VP_d \quad C_e = \sqrt{\frac{VP}{|SP_h|}} \quad VP_{ave} = \left(\frac{\sqrt{VP_1} + \sqrt{VP_2} + \dots + \sqrt{VP_n}}{n} \right)^2 \quad VP_r = \left(\frac{Q_1}{Q_3} \right) VP_1 + \left(\frac{Q_2}{Q_3} \right) VP_2$$

$$V = 1096 \sqrt{\frac{VP}{\rho}} \quad Q = 4005 C_e A \sqrt{|SP_h|} \quad Q = 4005 A \sqrt{\frac{SP_h}{df(1 + F_h)}} \quad Q = 1096 A \sqrt{\frac{SP_h}{\rho(1 + F_h)}} \quad Q_{cor} = Q_{design} \sqrt{\frac{SP_{gov}}{SP_{duct}}}$$

$$Q' = \frac{Q}{K} \quad t_2 - t_1 = -\frac{V_r}{Q'} \ln \left(\frac{C_2}{C_1} \right) \quad \ln \left(\frac{G - Q' C_2}{G - Q' C_1} \right) = -\frac{Q'(t_2 - t_1)}{V_{room}} \quad C = \left(\frac{G}{Q'} x 10^6 \right) + C_{supply}$$

$$N_{changes} = \frac{60Q}{V_{room}} \quad C = \frac{G}{Q'} (1 - e^{-Nt/60}) x 10^6 \quad C = C_0 e^{-tN_{changes}} \quad Q = \frac{(403)(s.g.)(ER)(K)(10^6)}{(m.w.)(C)} \quad C = \frac{gx24.45x10^6}{MWxV}$$

$$Q_2 = Q_1 \left(\frac{Size_2}{Size_1} \right)^3 \left(\frac{RPM_2}{RPM_1} \right) \quad P_2 = P_1 \left(\frac{Size_2}{Size_1} \right)^2 \left(\frac{RPM_2}{RPM_1} \right)^2 \quad PWR_2 = PWR_1 \left(\frac{Size_2}{Size_1} \right)^5 \left(\frac{RPM_2}{RPM_1} \right)^3$$

$$FSP = SP_{out} - SP_{in} - VP_{in} \quad FTP = TP_{out} - TP_{in}$$

NOISE

$$SPL = 20 \left(\log \frac{P}{P_0} \right) \quad SPL = 10 \left(\log \frac{I}{I_0} \right) \quad SPL_2 = SPL_1 + 20 \log \left(\frac{d_1}{d_2} \right)$$

$$SPL_f = 10 \log \sum 10^{\frac{SPL}{10}} \quad SPL_f = SPL_I + 10 \log(n) \quad L_w = 10 \log \left(\frac{W}{W_0} \right) \quad W_0 = 10^{-12} \text{ watts}$$

$$L_{Total} = L_1 + 10 \log \left(10^{\frac{L_2 - L_1}{10}} + 1 \right) \quad L_{eq} = 10 \log \left(\frac{1}{T} \sum_{i=1}^N \left(10^{\frac{L_i}{10}} t_i \right) \right) \quad L_{PT} = 10 \log \left(\sum_{i=1}^N 10^{\frac{L_{Pi}}{10}} \right) \quad TL = 10 \log \left(\frac{E_i}{E_t} \right)$$

$$L_p = L_w - 20 \log_{10} r - 0.5 + DI + T \quad DI = 10 \log_{10} Q \quad \%D = 100 \left(\frac{C_1}{T_1} + \frac{C_2}{T_2} + \dots + \frac{C_i}{T_i} \right)$$

$$T = 8/2^{(level-85)/3} \quad TWA_{eq} = 10 \log \left(\frac{\%D}{100} \right) + 85dBA \quad TWA = 16.61 \log \left(\frac{\%D}{100} \right) + 90dBA \quad f = \frac{(N)(RPM)}{60}$$

$$f = \frac{c}{\lambda} \quad f_2 = 2f_1 \quad f_c = \sqrt{f_1 f_2} \quad f_2 = \sqrt{2} f_1 \quad f_2 = \sqrt[3]{2} f_1$$

USEFUL EQUATIONS FOR THE ABIH EXAMINATIONS

This list of equations is offered as assistance in taking the ABIH examinations. No assurance is given that this list is complete or that the use of this list will assure the successful completion of any examination. The variables used are the same as found in the reference source for the equation. No attempt has been made to standardize variables.

GENERAL SCIENCES, STATISTICS, STANDARDS

$$ppm = \frac{V_{contam}}{V_{air}} \times 10^6 \quad ppm = \frac{P_v}{P_{atm}} \times 10^6 \quad ppm = \frac{mg / m^3 \times 24.45}{m.w.} \quad \frac{P_1 V_1}{n R T_1} = \frac{P_2 V_2}{n R T_2} \quad V_{TS} = \frac{g d_p^2 (\rho_p - \rho_a)}{18 \eta}$$

$$R_e = \frac{\rho d v}{\eta} \quad \log \frac{I_o}{I} = abc \quad pH = -\log_{10}[H^+] \quad K_a = \frac{[H^+]x[A^-]}{[HA]} \quad K_b = \frac{[BH^+]x[OH^-]}{[B]}$$

$$P_{total} = X_1 P_1 + X_2 P_2 + \dots + X_i P_i \quad \text{vapor/hazard ratio} = \frac{\text{sat. concentration}}{\text{exposure guideline}} \quad TLV_{mix} = \frac{C_1}{TLV_1} + \frac{C_2}{TLV_2} + \dots + \frac{C_n}{TLV_n}$$

$$TLV_{mix} = \frac{1}{\frac{F_1}{TLV_1} + \frac{F_2}{TLV_2} + \dots + \frac{F_n}{TLV_n}} \quad RF = \frac{8}{h} x \frac{24-h}{16} \quad RF = \frac{40}{h_w} x \frac{168-h_w}{128} \quad C_{asb} = \frac{(C_s - C_b)A_c}{1000 A_f V_s} \quad C_{asb} = \frac{EA_c}{1000 V_s}$$

$$E_{fiber\ density} = \frac{\frac{f}{N_f} - \frac{B}{N_b}}{A_f} \quad d = \frac{0.61 \lambda}{\eta \sin \alpha} \quad \bar{X} = \frac{X_1 + X_2 + \dots + X_n}{n} \quad SD = \sqrt{\frac{\sum (x - \bar{x})^2}{n-1}} \quad GM = \sqrt[n]{(x_1)(x_2)\dots(x_n)}$$

$$GM = 10^{\frac{\sum (\log x)}{n}} \quad GSD = \frac{84.13\% \text{ tile value}}{50\% \text{ tile value}} \quad GSD = \frac{50\% \text{ tile value}}{15.87\% \text{ tile value}} \quad SAE = 1.645 CV_{total} \quad CV = \frac{SD}{\bar{X}}$$

$$E_c = \sqrt{E_1^2 + E_2^2 + \dots + E_n^2} \quad t = \frac{\bar{x}_1 - \bar{x}_2}{SD_{pooled} \sqrt{\frac{1}{n_1} + \frac{1}{n_2}}} \quad SD_{pooled} = \sqrt{\frac{(n_1 - 1)SD_1^2 + (n_2 - 1)SD_2^2}{n_1 + n_2 - 2}}$$

$$LCL = \frac{C_A}{PEL} - \frac{SAE \sqrt{T_1^2 C_1^2 + T_2^2 C_2^2 + \dots + T_n^2 C_n^2}}{PEL(T_1 + T_2 + \dots + T_n)} \quad 95\% \text{ Conf} = \bar{X} \pm 1.645 \frac{SD}{\sqrt{n}} \quad 95\% \text{ Conf} = \bar{X} \pm 1.96 \frac{SD}{\sqrt{n}}$$

HEAT STRESS

$$WBGT = 0.7t_{nwb} + 0.2t_g + 0.1t_{db} \quad WBGT = 0.7t_{nwb} + 0.3t_g \quad \Delta S = (M - W) \pm C \pm R - E \quad R = 15(t_w - 95)$$

$$C = 0.65v^{0.6}(t_a - 95) \quad E_{max} = 2.4v^{0.6}(42 - vp_w) \quad cfm = \frac{\text{Total Sensible Heat (BTU / hr)}}{1.08(\Delta T)} \quad HSI = \frac{E_{req}}{E_{max}} \times 100$$

USEFUL EQUATIONS FOR THE ABIH EXAMINATIONS

This list of equations is offered as assistance in taking the ABIH examinations. No assurance is given that this list is complete or that the use of this list will assure the successful completion of any examination. The variables used are the same as found in the reference source for the equation. No attempt has been made to standardize variables.

RADIATION

$$I_2 = I_1 \left(\frac{d_1}{d_2} \right)^2 \quad \text{Rem} = (\text{RAD})(\text{QF}) \quad D = \frac{\Gamma A}{d^2} \quad A = A_i (0.5)^{\frac{t}{T_{1/2}}} \quad A_i = \frac{0.693}{T_{1/2}} N_i \quad A = A_i e^{\frac{-0.693t}{T_{1/2}}}$$

$$I = (1/2)^A I_0 \quad I = (1/10)^B I_0 \quad I_2 = \frac{I_1}{\frac{X}{2^{HVL}}} \quad I_2 = \frac{I_1}{10^{\frac{X}{TVL}}} \quad X = 3.32 \log \left(\frac{I_1}{I_2} \right) (\text{HVL}) \quad I = I_0 B e^{-\mu x}$$

$$\frac{1}{T_{1/2\text{eff}}} = \frac{1}{T_{1/2\text{rad}}} + \frac{1}{T_{1/2\text{bio}}} \quad T_{1/2\text{eff}} = \frac{(T_{1/2\text{rad}})(T_{1/2\text{bio}})}{T_{1/2\text{rad}} + T_{1/2\text{bio}}} \quad PD = \frac{E^2}{3770} \quad PD = 37.7 H^2 \quad W = \frac{4P}{A} \quad r = \left(\frac{PG}{4\pi EL} \right)^{1/2}$$

$$B_r = \sqrt{B_x^2 + B_y^2 + B_z^2} \quad r_{\text{NHZ}} = \frac{1}{\phi} \left(\frac{4\Phi}{\pi EL} - a^2 \right)^{1/2} \quad r_{\text{NHZ}} = \frac{f_0}{b_0} \left(\frac{4\Phi}{\pi EL} \right)^{1/2} \quad r_{\text{NHZ}} = \left(\frac{\rho\Phi \cos \theta}{\pi EL} \right)^{1/2} \quad D_s = \frac{1}{\phi} \left(\frac{4\Phi}{\pi TL} - a^2 \right)^{1/2}$$

$$\text{spatial ave} = \left(\frac{\sum_{i=1}^N FS_i^2}{N} \right)^{1/2} \quad t = \frac{0.003 \text{ J/cm}^2}{E_{\text{eff}}} \quad t = \frac{EL}{ML} \times 0.1 \text{ h} \quad O.D. = \log \frac{I_0}{I} \quad D_L = \sqrt{a^2 + \phi^2 r^2}$$

$$I_2 = I_1 x (\text{magnification})^2 \quad G = 10^{g/10}$$

CONSTANTS AND CONVERSIONS

$$^{\circ}\text{F} = 9/5(^{\circ}\text{C}) + 32 \quad ^{\circ}\text{R} = ^{\circ}\text{F} + 460 \quad \text{K} = ^{\circ}\text{C} + 273.15 \quad \text{molar volume at } 25^{\circ}\text{C, } 1 \text{ atm} = 24.45 \text{ L} \quad 1 \text{ ft}^3 = 28.32 \text{ L}$$

$$1 \text{ ft}^3 = 7.481 \text{ U.S. gal} \quad 1 \text{ L} = 1.0566 \text{ qt} \quad 1 \text{ inch} = 2.54 \text{ cm} \quad 1 \text{ lb} = 453.6 \text{ gm} \quad 1 \text{ gram} = 15.43 \text{ grains}$$

$$1 \text{ atm} = 14.7 \text{ psi} = 760 \text{ mm Hg} = 29.92 \text{ in Hg} = 33.93 \text{ ft water} = 1013.25 \text{ mbar} = 101,325 \text{ pascals}$$



$$1 \text{ Currie} = 3.7 \times 10^{10} \text{ disint/sec (Becquerel)} = 2.2 \times 10^{12} \text{ dpm} \quad 1 \text{ Gray} = 100 \text{ Rad} \quad 1 \text{ Sievert} = 100 \text{ Rem}$$

$$1 \text{ Tesla} = 10,000 \text{ Gauss} \quad 1 \text{ BTU} = 1054.8 \text{ joules} = 0.293 \text{ watt hr} \quad 1 \text{ cal} = 4.184 \text{ joules}$$

$$\text{speed of sound in air at } 20^{\circ}\text{C} = 1130 \text{ ft/sec} \quad \text{speed of light} = 3 \times 10^8 \text{ m/sec}$$

$$\text{Planck's constant} = 6.626 \times 10^{-27} \text{ erg sec} \quad \text{Avogadro's number} = 6.024 \times 10^{23} \quad \text{gas constant, R} = 8.314 \text{ J/mole K}$$

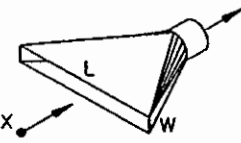
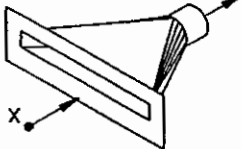
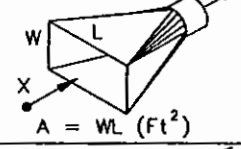
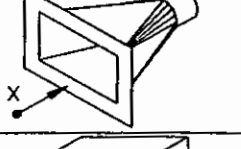
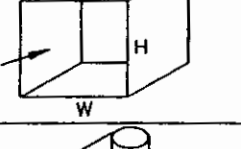
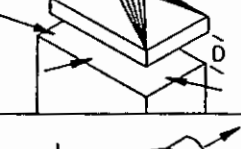
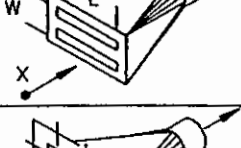
$$g = 981 \text{ cm/sec}^2 = 32 \text{ ft/sec}^2 \quad A_c = 385 \text{ mm}^2 \text{ for } 25 \text{ mm filter} \quad \text{density of air} = 1.29 \text{ g/L at } 1 \text{ atm, } 0^{\circ}\text{C}$$

HOOD TYPE	DESCRIPTION	ASPECT RATIO, W/L	AIR FLOW
	SLOT	0.2 OR LESS	$Q = 3.7 LVX$
	FLANGED SLOT	0.2 OR LESS	$Q = 2.6 LVX$
	PLAIN OPENING	0.2 OR GREATER AND ROUND	$Q = V(10X^2 + A)$
	FLANGED OPENING	0.2 OR GREATER AND ROUND	$Q = 0.75V(10X^2 + A)$
	BOOTH	TO SUIT WORK	$Q = VA = VWH$
	CANOPY	TO SUIT WORK	$Q = 1.4 PVD$ SEE FIG. VS-99-03 P = PERIMETER D = HEIGHT ABOVE WORK
	PLAIN MULTIPLE SLOT OPENING 2 OR MORE SLOTS	0.2 OR GREATER	$Q = V(10X^2 + A)$
	FLANGED MULTIPLE SLOT OPENING 2 OR MORE SLOTS	0.2 OR GREATER	$Q = 0.75V(10X^2 + A)$

AMERICAN CONFERENCE
OF GOVERNMENTAL
INDUSTRIAL HYGIENISTS

HOOD TYPES

DATE 4-96

FIGURE 3-11

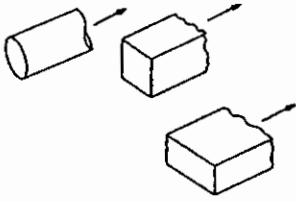
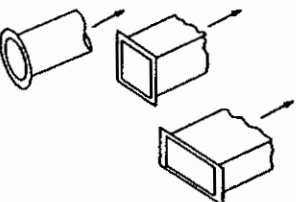
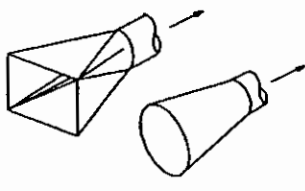
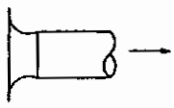
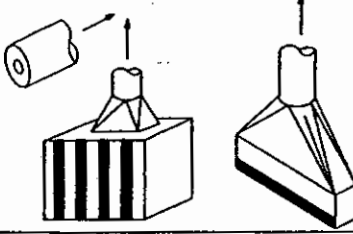
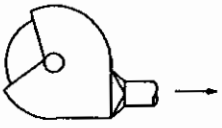
HOOD TYPE	DESCRIPTION	HOOD ENTRY LOSS (F _L) COEFFICIENT
	PLAIN OPENING	0.93
	FLANGED OPENING	0.49
	TAPER OR CONE HOOD	SEE CHAPTER 10
	BELL MOUTH INLET	0.04
	ORIFICE	SEE CHAPTER 10
	TYPICAL GRINDING HOOD	(STRAIGHT TAKEOFF) 0.65
		(TAPERED TAKEOFF) 0.40
AMERICAN CONFERENCE OF GOVERNMENTAL INDUSTRIAL HYGIENISTS		<p style="text-align: center;"><i>HOOD LOSS COEFFICIENTS</i></p> <p>DATE <i>4-96</i> FIGURE <i>3-16</i></p>

From American Conference of Governmental Industrial Hygienists: Industrial Ventilation: A Manual of Recommended Practice, 24th Edition; Copyright 2001, Cincinnati, Ohio. Reprinted with permission.



$h_e = 0.93 VP_d$
PLAIN DUCT END



$h_e = 0.49 VP_d$
FLANGED DUCT END

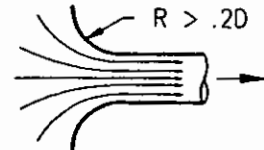

$h_e = 0.04 VP_d$
BELLMOUTH ENTRY

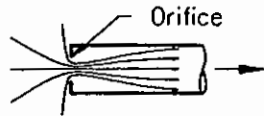

$h_e = 1.78 VP_{Orifice}$
SHARP-EDGED
ORIFICE

* $h_e = F_h VP_d$ See 3.5.1

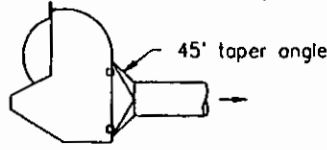

$h_e = 0.4 VP_d$ (topered take-off)
 $h_e = 0.65 VP_d$ (no toper)
STANDARD GRINDER HOOD

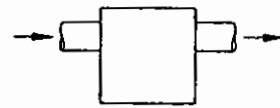

$h_e = 1.5 VP_d$
TRAP OR SETTLING CHAMBER

TAPERED HOODS

Flanged or unflanged; round, square or rectangular. θ is the major angle on rectangular hoods.

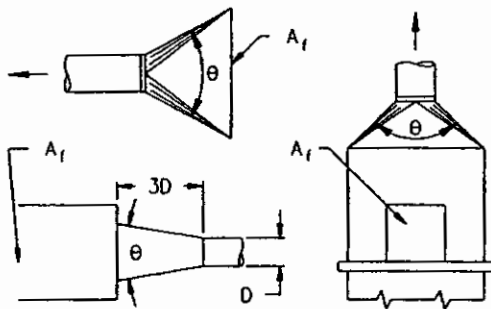

Face area (A_f) at least 2 times the duct area.

θ	ENTRY LOSS (h_e)	
	ROUND	RECTANGULAR
15°	0.15 VP	0.25 VP
30°	0.08 VP	0.16 VP
45°	0.06 VP	0.15 VP
60°	0.08 VP	0.17 VP
90°	0.15 VP	0.25 VP
120°	0.26 VP	0.35 VP
150°	0.40 VP	0.48 VP
180°	0.50 VP	0.50 VP

VP = Duct VP = VP_d
Note: 180° values represent round ducts butted into back of booth or hood without a rectangular to round transition.

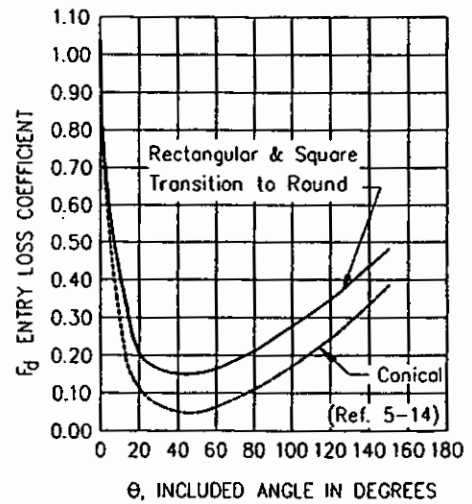

COMPOUND HOODS

A compound hood, such as the slot/plenum shown to the right, would have 2 losses, one through the slot and the other through the transition into the duct.

The slot entry loss coefficient, F_s , would have a value typically in the range of 1.00 to 1.78 (see Chapters 3 and 10).

The duct entry loss coefficient is given by the above data for tapered hoods.

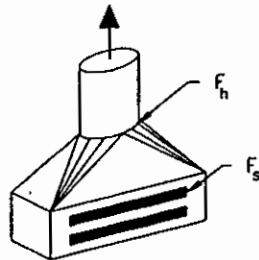

$$h_e = F_s VP_s + F_h VP_d$$

MISCELLANEOUS VALUES

HOOD	ENTRY LOSS COEFFICIENT F_h
Abrasive blast chamber	1.0
Abrasive blast elevator	2.3
Abrasive separator	2.3
Elevators (enclosures)	0.69
Flanged pipe plus close elbow	0.8
Plain pipe plus close elbow	1.60

AMERICAN CONFERENCE
OF GOVERNMENTAL
INDUSTRIAL HYGIENISTS

HOOD ENTRY LOSS COEFFICIENTS

DATE 1-95

FIGURE 5-15

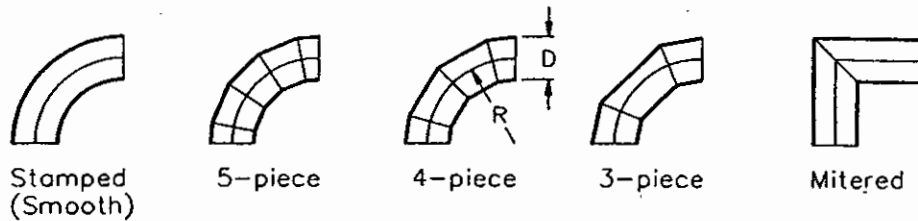

	R/D					
	0.5	0.75	1.00	1.50	2.00	2.50
Stamped	0.71	0.33	0.22	0.15	0.13	0.12
5-piece	-	0.46	0.33	0.24	0.19	0.17*
4-piece	-	0.50	0.37	0.27	0.24	0.23*
3-piece	0.90	0.54	0.42	0.34	0.33	0.33*

* extrapolated from published data

OTHER ELBOW LOSS COEFFICIENTS

Mitered, no vanes 1.2
 Mitered, turning vanes 0.6
 Flatback (R/D = 2.5) 0.05 (see Figure 5-23)

NOTE: Loss factors are assumed to be for elbows of "zero length." Friction losses should be included to the intersection of centerlines.

ROUND ELBOW LOSS COEFFICIENTS

(Ref. 5.13)

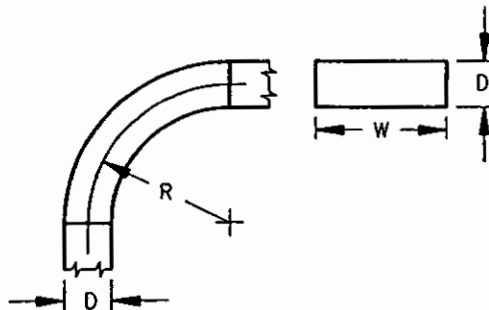

R/D	Aspect Ratio, W/D					
	0.25	0.5	1.0	2.0	3.0	4.0
0.0 (Mitered)	1.50	1.32	1.15	1.04	0.92	0.86
0.5	1.36	1.21	1.05	0.95	0.84	0.79
1.0	0.45	0.28	0.21	0.21	0.20	0.19
1.5	0.28	0.18	0.13	0.13	0.12	0.12
2.0	0.24	0.15	0.11	0.11	0.10	0.10
3.0	0.24	0.15	0.11	0.11	0.10	0.10

SQUARE & RECTANGULAR ELBOW LOSS COEFFICIENTS

AMERICAN CONFERENCE
 OF GOVERNMENTAL
 INDUSTRIAL HYGIENISTS

DUCT DESIGN DATA
 ELBOW LOSSES

DATE 1-95 FIGURE 5-16

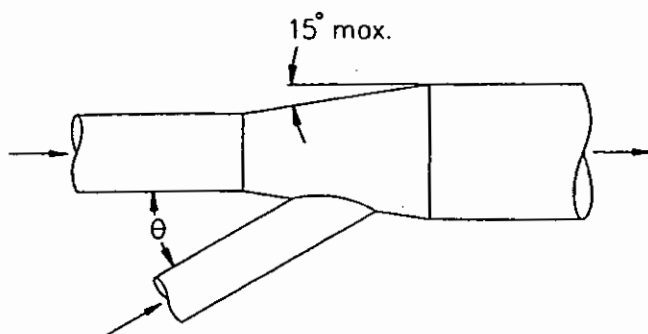

Note: Branch entry loss assumed to occur in branch and is so calculated.

Do not include an enlargement regain calculation for branch entry enlargements.

Angle θ Degrees	Loss Fraction of VP in Branch
10	0.06
15	0.09
20	0.12
25	0.15
30	0.18
35	0.21
40	0.25
45	0.28
50	0.32
60	0.44
90	1.00

BRANCH ENTRY LOSSES

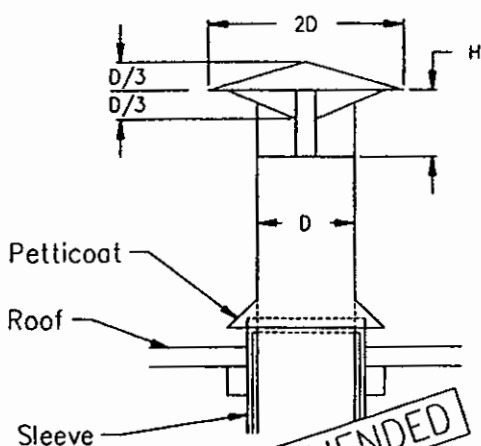

H, No. of Diameters	Loss Fraction of VP
1.0 D	0.10
0.75 D	0.18
0.70 D	0.22
0.65 D	0.30
0.60 D	0.41
0.55 D	0.56
0.50 D	0.73
0.45 D	1.0

WEATHER CAP LOSSES

See Fig. 5-30

AMERICAN CONFERENCE
OF GOVERNMENTAL
INDUSTRIAL HYGIENISTS

DUCT DESIGN DATA

DATE 1-95

FIGURE 5-17

STATIC PRESSURE REGAINS FOR EXPANSIONS

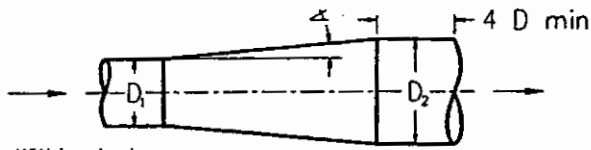

Within duct

Regain (R), fraction of VP difference					
Taper angle degrees	Diameter ratios D_2/D_1				
	1.25:1	1.5:1	1.75:1	2:1	2.5:1
3 1/2	0.92	0.88	0.84	0.81	0.75
5	0.88	0.84	0.80	0.76	0.68
10	0.85	0.76	0.70	0.63	0.53
15	0.83	0.70	0.62	0.55	0.43
20	0.81	0.67	0.57	0.48	0.43
25	0.80	0.65	0.53	0.44	0.28
30	0.79	0.63	0.51	0.41	0.25
Abrupt 90	0.77	0.62	0.50	0.40	0.25

Where: $SP_2 = SP_1 + R(VP_1 - VP_2)$

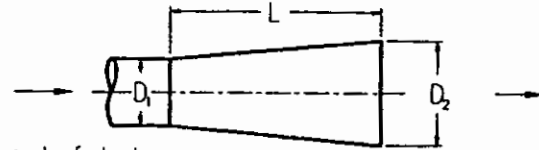

At end of duct

Regain (R), fraction of inlet VP						
Taper length to inlet diam L/D	Diameter ratios D_2/D_1					
	1.2:1	1.3:1	1.4:1	1.5:1	1.6:1	1.7:1
1.0:1	0.37	0.39	0.38	0.35	0.31	0.27
1.5:1	0.39	0.46	0.47	0.46	0.44	0.41
2.0:1	0.42	0.49	0.52	0.52	0.51	0.49
3.0:1	0.44	0.52	0.57	0.59	0.60	0.59
4.0:1	0.45	0.55	0.60	0.63	0.63	0.64
5.0:1	0.47	0.56	0.62	0.65	0.66	0.68
7.5:1	0.48	0.58	0.64	0.68	0.70	0.72

Where: $SP_1 = SP_2 - R(VP_1)$

When $SP_2 = 0$ (atmosphere) SP_1 will be (-)

The regain (R) will only be 70% of value shown above when expansion follows a disturbance or elbow (including a fan) by less than 5 duct diameters.

STATIC PRESSURE LOSSES FOR CONTRACTIONS

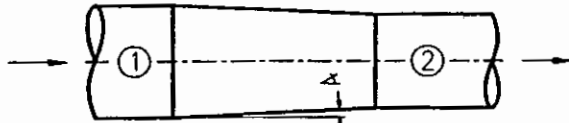

Tapered contraction
 $SP_2 = SP_1 - (VP_2 - VP_1) - L(VP_2 - VP_1)$

Taper angle degrees	L(loss)
5	0.05
10	0.06
15	0.08
20	0.10
25	0.11
30	0.13
45	0.20
60	0.30
over 60	Abrupt contraction

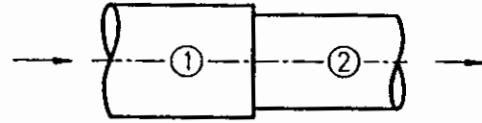

Abrupt contraction
 $SP_2 = SP_1 - (VP_2 - VP_1) - K(VP_2)$

Ratio A_2/A_1	K
0.1	0.48
0.2	0.46
0.3	0.42
0.4	0.37
0.4	0.32
0.6	0.26
0.7	0.20

$A =$ duct area, ft^2

Note:

In calculating SP for expansion or contraction use algebraic signs: VP is (+), and usually SP is (+) in discharge duct from fan, and SP is (-) in inlet duct to fan.

AMERICAN CONFERENCE
OF GOVERNMENTAL
INDUSTRIAL HYGIENISTS

DUCT DESIGN DATA

DATE 1-95 FIGURE 5-18