



Candidate Handbook

Certified Industrial Hygienist – CIH

6015 W. St. Joseph, Suite 102
Lansing, MI 48917
(517) 321-2638 Phone
(517) 321-4624 Fax
www.abih.org
abih@abih.org

Table of Contents

Application Requirements

General	1
Academic Requirements	1
Industrial Hygiene Coursework	1
Experience Requirements	2
References	3
Re-applicants	3
Application/Re-application Dates	3
Fees	4

Examination Information

General	5
Examination Procedures	5
Scoring of Examinations	6
Examination Preparation	6
Sample Questions	7
References	8
Job Analysis - Examination Blueprint	9
Rubric Definitions	14
Equation Sheet	15

APPLICATION REQUIREMENTS

GENERAL

To qualify for admission to the ABIH examinations, an applicant must comply with all regulations of the Board that are in effect at the time the application is filed. An applicant must:

- Meet academic requirements/IH coursework
- Meet a professional industrial hygiene experience requirement supported by references
- Be in the current practice of industrial hygiene

All applicants are evaluated without regard to age, sex, race, religion, national origin, disability or marital status.

All applicants must agree to adhere to the ABIH Code of Ethics and be governed by the ABIH Ethics Case Procedures.

All application materials, including transcripts, references, and educational coursework (including ethics) must be postmarked by February 1 for the Spring examination or August 1 for the Fall examination.

When initial review of an application/reapplication indicates that pertinent information is not clear, supplemental information may be requested from the applicant. In that case, review of the application/reapplication will not proceed until the requested information is received.

Directors of the Board are not authorized to give an opinion to any applicant as to his/her eligibility, either before or after an application is filed.

As part of the ABIH **record-retention** program, files that have been inactive for three years will be destroyed. Prior to destroying a file, the staff will attempt to notify the applicant using their last known address.

ACADEMIC REQUIREMENTS

Graduation from a regionally accredited college or university, or other college acceptable to the Board, with a Bachelors Degree in biology, chemistry, physics, engineering, or an ABET accredited program in industrial hygiene or safety is accepted.

The Board will consider, and may accept, any other Bachelors Degree from an acceptable college or university so long as the degree is based upon appropriate coursework and represents at least 60 semester hours of creditable subjects, with at least 15 of those hours at the upper level (junior, senior or graduate level). Creditable subjects are undergraduate or graduate level courses in science, mathematics, engineering and science-based technology. An applicant who is found to have an unacceptable bachelor's degree may remedy that degree with additional academic science coursework from an acceptable college or university, or by completion of an acceptable cognate graduate degree.

Academic credit granted by a college or university based upon a candidate's activities unrelated to appropriate coursework will

not be accepted by ABIH. For example, the completion of the Graduate Record Examination (GRE), College Level Examination Program (CLEP) examinations, DANTES Subject Standardized Tests (DSSTs), and/or other similar equivalency credits granted by an institution for work/life experience are not considered educational courses for the purpose of satisfying the academic certification eligibility requirements.

The social sciences are not considered to be qualifying sciences. Evaluation of the science content of a bachelor's degree will be made from the official transcripts. When further information about the content of a degree, such as course descriptions or content is required, the applicant will be requested to provide the information and review of the degree will not proceed until the information is received.

Official transcripts for each degree are required. An official transcript is one sent directly to ABIH by the college or university or, as an alternative, the applicant may submit official transcripts if they are in a sealed envelope with the registrar's stamp across the seal. When a degree includes credits which were transferred from another college or university, official transcripts for those course credits must be sent upon request.

The Board will consider a U.S. college or university to be acceptable when it holds institutional accreditation from one of the six Regional Accrediting Bodies or the Distance Education and Training Council which are recognized by the Council for Higher Education Accreditation (CHEA) and the US Department of Education. The degree must be awarded during the time for which the institutional accreditation was issued.

A college or university which is located outside the U.S./Canada will be considered for acceptability on the basis of its accreditation status in the education system which has jurisdiction. Applicants with international degrees will be required to submit their transcript(s) to a member of the National Association of Credential Evaluation Services, Inc. (www.naces.org) and request that a report be forwarded to ABIH. If the degree is in biology, chemistry, engineering or physics, a General/Document-by-Document report must be provided. Any other degree requires a Comprehensive/Course-by-Course report. If you have several degrees and at least one of them is from the U.S./Canada, a transcript evaluation may not be required for your international degree(s). Please contact the office (abih@abih.org ; 517-321-2638 Ext 3) for advice.

If you are considering additional certifications by an organization other than ABIH, you should consult that organization's website for international degree requirements.

INDUSTRIAL HYGIENE COURSEWORK

The Board requires applicants to document completion of 180 academic contact hours or 240 continuing education contact hours of specific industrial hygiene courses. At least half of the required coursework (90 academic or 120 continuing education contact hours) must cover the broad subjects of industrial hygiene toxicology, fundamentals of industrial hygiene, measurements and controls.

Acceptable toxicology courses will cover the essential aspects of toxicology (adverse effects of chemicals on living systems) with an emphasis on humans. Topics covered are likely to include dose response relationships; absorption, distribution, metabolism and excretion of toxic substances in the body; biotransformation; organ systems; chemical carcinogenesis & mutagenesis; etc.

Fundamentals courses are likely to address recognizing hazards/stressors found in the work environment. This includes chemical, physical (noise, radiation, thermal), biological and ergonomic stressors.

Measurement courses and control (engineering, substitution, administrative, PPE) courses will address the same four broad stressor categories as fundamentals (chemical, physical, biological and ergonomic).

The remaining coursework may be in industrial hygiene subjects that are narrower in scope (i.e. asbestos, lead, mold, confined space entry, etc.). Regulatory refresher courses can only be counted once.

The IH Coursework requirement can be satisfied if the necessary contact hours were completed as part of the applicant's academic degree.

If additional coursework is taken to meet this requirement, then academic courses, continuing education courses or a combination of both can be submitted. One semester hour equals 15 academic contact hours and one quarter hour equals 10 academic contact hours. One CEU equals 10 continuing education contact hours. For documentation of continuing education contact hours, copies of certificates need to be sent with the application. **If the number of contact hours or CEUs are not on the certificate, an agenda must be included.**

New applicants are required to document that they have completed at least two contact hours of coursework in ethics. This will count as part of the current Industrial Hygiene coursework requirement. Credit for ethics is capped at five contact hours.

EXPERIENCE REQUIREMENTS

Four years of employment in the professional practice of industrial hygiene acceptable to the Board are required to be eligible for examination.

To be recognized as "**professional level**" work, the experience must include:

- Independence of actions – relates to the amount of planning, self-direction, decision-making and autonomy involved in the work experience;
- A depth of work requirements – relates to the extent to which work experience requires data-gathering, analysis and interpretation;
- Level of interaction – relates to the degree to which the individual interacts with a broad spectrum of contacts, including decision-makers; and

- Responsibility for work outcome – relates to accuracy and extent to which the individual is held accountable for his/her work and decisions.

"**Technician or pre-professional**" experience is not creditable towards eligibility.

Creditable experience is expected to include the continuum of the process of Industrial Hygiene practice which is anticipation, recognition, evaluation, control and management of occupational health hazards.

Experience credit may be given for research, teaching or Industrial Hygiene program administration if done at a professional level. Research or teaching done as a student does not earn experience credit.

After receipt of an acceptable bachelors' degree, a masters student in an ABET accredited industrial hygiene program or an industrial hygiene doctoral student may be considered to be in "industrial hygiene practice" for the purpose of determining his/her eligibility for examination. However, only the **completed** advanced degree will be credited towards experience equivalency.

An applicant who is otherwise qualified, but whose industrial hygiene career has been interrupted for one year or less for graduate studies in a cognate science, medical reason, unemployment, or the like, may be considered to be "in practice" for purpose of determining examination eligibility. The time spent out of practice will not receive experience credit toward any future examination.

A candidate must also be practicing "**broad scope**" industrial hygiene. Two dimensions are evaluated in judging the scope of experience:

1. "work function" includes the continuum of the process of Industrial Hygiene practice, which is anticipation, recognition, evaluation, control and management of occupational health hazards. Although no proportion of time devoted to each of these aspects is prescribed, broad-scope practice must exhibit experience in the entire process;
2. "stressor category" includes four generic categories of occupational health stressors: chemical, physical, biological and ergonomic. Experience is expected in at least two of these four stressors.

Professional-level experience which does not meet the broad-scope criteria will be considered narrow-scope experience. A maximum of one year of narrow-scope experience may be credited towards eligibility.

A **maximum** of one year of **experience equivalency** may be credited for industrial hygiene degrees from institutions acceptable to the Board. For bachelors level industrial hygiene degrees, six months experience credit will be awarded only when the program is accredited by the accreditation Board for Engineering & Technology (ABET). For masters level industrial hygiene degrees awarded after December 31, 1996, one year

experience credit will be awarded only when the program is accredited by ABET. One year may be granted for an acceptable doctoral degree, provided that the graduate degree is in industrial hygiene and that all academic requirements have been completed.

REFERENCES

A minimum of two professional references must be provided.

A reference from an applicant's current supervisor is required to document current industrial hygiene practice.

There must be a reference from the applicant's immediate supervisor(s) covering the entire time period for which the applicant requests experience credit. When an applicant is/was a principal in a business, the Board will accept references from major clients.

There must also be a reference from a **CIH** who is familiar with the applicant's industrial hygiene work and can describe, from first hand experience, the nature of the applicant's industrial hygiene responsibilities. The CIH reference may also be a supervisory reference.

In the event that no **CIH** is available who is familiar with the applicant's industrial hygiene work, the applicant may substitute a reference from an individual certified at the professional level by an organization whose industrial/occupational hygiene certification scheme has been recognized by the International Occupational Hygiene Association/IOHA. Another alternative is to provide three written work examples which demonstrate a range of industrial hygiene activities. The examples must span the time period being claimed as professional level experience and be identifiable as the applicant's own work. Work examples will not be returned unless specifically requested.

Each reference must be provided on the Board's Professional Reference Questionnaire form, have an original signature and be prepared only by the person giving the reference. It is **unacceptable** for the applicant to complete the form and have it signed by his or her reference.

Each Professional Reference Questionnaire must be mailed or faxed directly to ABIH by the person giving the reference.

An applicant's spouse or other relative, a person whom the applicant supervises, or a member of the Board may not act as a reference for an applicant. References are not accepted if written by the applicant.

A Professional Reference Questionnaire which does not comply with the requirements of this section will not be accepted by ABIH.

Each Professional Reference Questionnaire shall remain confidential between the author and ABIH.

TEST ACCOMODATIONS

The American Board of Industrial Hygiene (ABIH) provides reasonable accommodations, in accordance with the Americans with Disabilities Act as amended and other applicable laws, for individuals with documented disabilities who demonstrate a need for accommodations. In accordance with the Americans with Disabilities Act, ABIH does not discriminate against individuals with disabilities in providing access to its examination program.

If a candidate has a documented disability and requires test accommodations, s/he must submit a Test Accommodation Request Form, which can be found on the ABIH website at www.abih.org/certified/index.html. The request must accompany the application form and be received by the normal application deadline (February 1/August 1).

REAPPLICANTS

A reapplicant whose original approval/reapproval was **less than two years ago** and who wishes to be examined/reexamined in an examination which was delayed/failed previously must notify ABIH in writing prior to appropriate deadlines when he/she wishes to take the approved examination, and submit a \$75.00 reapplication fee.

A reapplicant whose original approval/reapproval was **more than two years ago** and who wishes to be examined/reexamined in an examination which was delayed/failed previously must submit a Reapplication Form, a \$75.00 reapplication fee, a Professional Reference Questionnaire from a current supervisor and must meet all current eligibility standards including the completion of the required industrial hygiene coursework. The application deadlines of February 1 and August 1 apply.

If your file has been destroyed (due to being inactive for three years) all the requirements for new applicants must be followed.

APPLICATION/REAPPLICATION DATES

All documentation required to review an application or reapplication must be postmarked by February 1 when applying for the Spring examinations and by August 1 for the Fall examinations.

Examinations will be held twice each year at Prometric Testing Centers.

An applicant approved for the Spring exam can make an appointment with Prometric for April or May. Fall examinees can schedule for October or November.

FEES

Application fee \$150.00
Reapplication fee \$ 75.00

These fees are nonrefundable. However, an applicant/reapplicant declared ineligible for examination may resubmit or modify his/her application on the basis of new or supplemental information within two years of the filing date of the initial application without payment of an additional reapplication fee.

Examination fee \$350.00

This fee is nonrefundable. If an examination is cancelled with the testing center at least 48 hours in advance of the scheduled exam the fee will be carried over to your next approval. If your examination is not cancelled at least 48 hours in advance of the scheduled exam, the fee is forfeited.

An application/reapplication fee and examination fee are required for each exam taken.

Annual Renewal fee \$ 115.00

EXAMINATION INFORMATION

GENERAL

The examination is designed to test an individual's knowledge across the broad general practice of industrial hygiene. Questions may be expected in all rubrics (subject areas). The exam contains 250 questions.

All questions will be of multiple choice type and are selected to match the job analysis. The questions are not grouped by subject area in the examinations. The job analysis and rubric definitions currently in use by the Board can be found on pages 9-15 of this handbook.

Examinations are conducted in two sections, with three and one-half (3½) hours allotted for each section. There is a short tutorial prior to the examination and a short survey following the exam. There is an optional 60 minute break after the end of the first section. If this break is not ended early, the second section of the exam will begin after 60 minutes regardless of when you return from break.

EXAMINATION PROCEDURES

Scheduling Your Appointment

Your examination fee must be paid before you will be able to schedule an examination. You will not appear in Prometric's computer file of approved examinees until your examination fee has been paid.

To ensure that you obtain the location and date you prefer, you should call Prometric immediately or go online to schedule an appointment. We recommend that you schedule your appointment online since it is a faster and more efficient process. If you are scheduling by phone, call Prometric's Customer Service Contact Center (CSCC) at (800) 800-1123. Operators are available from 8:00 am to 8:00 pm (Eastern Time) Monday through Friday. If you are an international examinee please see the following list:

Australia and New Zealand (M-F, 8:30 to 17:00 GMT +10:00)
612-96405899
China (M-F 8:30 – 19:00 GMT +10:00)
8610-62799911
India (M-F, 9:00 to 17:30 GMT + 05:30)
91 124 4147700
Japan (M-F 8:30 – 19:00 GMT +10:00)
81 3 5541 4800
Korea (M-F 8:30 – 19:00 GMT +10:00)
82 2 2116 8331 or 1566 0990
South East Asia (M-F, 8:00 to 20:00 GMT +08:00)
60 3 7628 3333
Europe (M-F, 9:00 – 18:00GMT +10:00)
31 320 239 540
Middle East (Sunday-Thursday)
31 320 239 530
North Africa (Sunday-Thursday)
31 320 239 530
Sub-Saharan Africa (M-F, 9:00 – 18:00GMT +10:00)
31 320 239 593
Latin America (M-F, 9:00 to 5:00 Eastern Time)
443 751 4995

You will need to provide the following information when scheduling your appointment:

- your name
- your identification number (listed in the Authorization To Test or ATT letter)
- a daytime telephone number
- the name of the examination sponsor (ABIH)
- the examination you are taking (CIH)

If you are scheduling online, go to www.prometric.com/abih. You must have an email address to schedule online.

When you schedule your appointment either by telephone or online, you will receive a confirmation number. Make sure you keep a record of your confirmation number and appointment information. You will need your confirmation number if you want to confirm, reschedule or cancel your appointment. **You will not receive written notification concerning your appointment if you schedule via telephone.** If you schedule online, you will receive email confirmation of your appointment.

Test Site Location

You may take your examination at Prometric Testing Centers (PTC) in the United States, Canada, Puerto Rico, Guam, US Samoa, the Virgin Islands and internationally. Determine the best PTC location for taking your examination by selecting **Locate a Test Center** on Prometric's web site www.prometric.com/abih. When scheduling your appointment, you should confirm the address of your test center and obtain directions. You may obtain directions to the PTC at Prometric's web site: www.prometric.com/abih or by calling CSCC.

Examination Window

The Spring testing window opens on April 1st and closes on May 31st. The Fall testing window opens October 1st and closes November 30th. **You must test during the window for which you are approved.** The test will be 3.5 hours in the morning with an optional 1 hour break and then 3.5 hours in the afternoon. There will be additional time allotted for a brief computer tutorial before the test begins and a brief survey afterwards.

Confirming Your Appointment

It is your responsibility to verify that you have been scheduled for the date, time and place you have requested. To confirm your appointment, you can either call (800) 800-1123 or the international number from the list under **Scheduling Your Appointment** and select the option for confirming your appointment or you may confirm your appointment online at www.prometric.com/abih. You can confirm your appointment online even if you scheduled your appointment via telephone.

Examination Day

You should arrive at the test center at least 30 minutes prior to your scheduled exam time. You will need to show one current, valid government-issued photo identification document with a signature (e.g., driver's license or passport). Security measures, including the capture of a digital fingerprint and information from your identification, including an image of your photo, will be implemented. You should also bring your "Authorization to Test" (ATT) letter from the Board. **If you do not provide the required identification and fully participate in the identity validation process during check-in and breaks, you will not be permitted to test and you will forfeit the testing fees.**

Examinees may bring one or two **non-programmable** calculators* selected from the approved list below. Any calculator within the series listed in the information provided to candidates is acceptable. Not all models within a series are listed because of the variety and the model changes that take place. For example, the listing of a Texas Instruments TI-30 as "approved" means that such models as the TI-30X, TI-30Xa, TI-30XII, TI-30XIIs are all acceptable. The Prometric instructions to their staff indicate this, so the person checking you in at the Prometric Test Center will be aware that these are acceptable calculators.

*Approved Calculator List:

Casio - Models FX-115, FX-250, FX-260, FX-300, FX-350
Hewlett-Packard - Models hp-9S, hp-10S, hp-30S, hp-300S
Note: hp-9G is not acceptable
Texas Instruments - Models TI-30, TI-34, TI-35, TI-36

Other than the approved calculators and the materials provided by the test centers for working out calculations, no other materials are allowed in the examination room by the examinee. Cell phones, pagers, watches, books, manuals, notes, PDAs or other electronic devices or reference materials as well as food and drinks are not allowed in the examination room.

The ABIH equation sheets and plates from the ACGIH "Ventilation Manual" will be available on the computer on which you are taking your exam when you click on the "Reference" button.

Canceling, Rescheduling and Missed Appointments

If you need to cancel, postpone or change your examination location, you must do so by noon at least two (2) business days prior to your appointment. You may cancel or reschedule by calling (800) 800-1123 or the international number from the list on the previous page. You will need to provide your confirmation number. **If you miss your appointment, you will not be rescheduled and you will forfeit the testing fees.** If you are late for your appointment, you may not be admitted. Late admission is at the discretion of the Prometric Testing Center. If you decide to delay your examination see your ATT letter for more details.

Problems with Prometric Scheduling and Testing

You should call ABIH at (517) 321-2638 if you encounter one of the following problems:

- you cannot schedule an exam because the Prometric operator does not have a file with your name and identification number
- you go to your scheduled appointment and you are unable to test due to Prometric technical or personnel difficulties.

SCORING OF EXAMINATIONS

The passing score is a total number of questions answered correctly. There is **no** penalty for incorrect answers (such as "number correct minus a percentage of the number of incorrect answers"). All questions have the same point value. A "passing" score is **not** required in each of the individual rubrics. It will be to the candidate's advantage to attempt to answer all questions.

A criterion-referenced passing score has been established by a panel of Certified Industrial Hygienists using appropriate standard setting procedures under the guidance of CASTLE Worldwide, Inc. The passing score for each subsequent administration of the certification examination is based on a statistical equating process which adjusts for fluctuations in difficulty levels across different versions of the examination. Equating is performed to help ensure that candidates are evaluated according to the same competency standard from year to year.

Each examinee is informed of his or her pass/fail status immediately after completing the examination. **These are preliminary results, pending verification by the examination consultants and ABIH.** Examinees will receive their official results in writing approximately four weeks after taking the examination. An examinee who fails an examination will be informed of his or her overall score. All examinees receive a performance report indicating scores in the individual subareas.

EXAMINATION PREPARATION

The Board encourages each candidate to consider his or her knowledge and experience in the light of the examination rubrics and assess recognized strengths and weaknesses. Self study, specific training and group discussions are recognized methods of improving perceived weaknesses. In order to familiarize candidates with the nature and form of questions which may be found in the examination, a selection of sample questions is included.

The Board supports professional education and training as essential to a person's continued and increased competence in the practice of industrial hygiene. Through its Certification Maintenance program the Board credits industrial hygiene courses, seminars, meetings, discussions, and the like for professional development. The Board does not endorse or support training courses, study guides, or other activities which are intended or purported only to be preparation for its examinations.

SAMPLE QUESTIONS

The following are provided as examples of the nature and type of questions which may be found in the Board's examinations. Their subject matter and level of difficulty do not necessarily reflect that which will be found in the examinations.

- A mixture contains:

50 mL benzene (m.w.=78) v.p.= 75 mm, Hg; sp. gr.= 0.879.
25 mL carbon tetrachloride (m.w. = 154), v.p. = 91 mm, Hg;
sp. gr. = 1.595
25 mL trichloroethylene (m.w. = 131.5), v.p. = 58 mm, Hg;
sp. gr. = 1.455.

Assuming Raoult's Law is obeyed, what will be the concentration of benzene in air at 760 mm Hg saturated with vapor of the above mixture?
 - 3.5%
 - 4.5%
 - 5.1%
 - 9.9%
- Which one of the following health effects may be manifested by chronic overexposure to benzene?
 - Abdominal colic
 - Bladder tumors
 - Cholinesterase depression
 - Leukemogenic cancer
- What is the ACGIH Threshold Limit Value for fluoride primarily intended to guard against?
 - delayed lung edema
 - mottling of tooth enamel
 - respiratory tract irritation
 - tubular kidney injury
- Under usual operating conditions, what is the static pressure at the discharge side of a fan with 10' length of discharge duct?
 - equal to the velocity pressure
 - less than the atmospheric pressure
 - equal to the total pressure
 - greater than the atmospheric pressure
- 1,000 cfm is to be drawn into a round, freely suspended duct of 6" diameter. What is the expected centerline velocity at 4" outside the duct opening?
 - 286 fpm
 - 534 fpm
 - 765 fpm
 - 915 fpm
- Two separate noise sources of 98 dBA and 96 dBA respectively are installed and operated together. What is the combined noise level?
 - 99 dBA
 - 100 dBA
 - 101 dBA
 - 194 dBA
- A maintenance worker must enter an empty reactor vessel for cleaning, inspection and lining repair. In the absence of continuous ventilation and testing of the air in the vessel, what should an industrial hygienist recommend?
 - an organic vapor respirator for the worker and a helper with a life line within earshot
 - performance of the work at night with prior notice to the city's Emergency Response Unit
 - flushing the tank with a suitable organic solvent before the worker enters
 - a SCBA and fixed life line for the worker and a helper directly outside the tank
- Workers in a brass foundry complain of a fever and general malaise on Mondays following a weekend respite from work. What should an industrial hygienist be equipped to obtain, upon arriving at the foundry?
 - blood samples to detect carbon monoxide exposures
 - air samples to measure exposures to zinc fume
 - potable water samples to detect PCB concentration
 - urine samples to measure exposures to lead
- What do the radioisotopes ^{238}U , ^{40}K , ^{226}Ra , and ^{235}U have in common?
 - Each is an alpha emitter.
 - Each is a neutron emitter.
 - Each occurs in nature.
 - Each has an analogue normally found in the human body.
- Why is stack sampling for particulate aerosols done in an isokinetic manner?
 - to avoid size discrimination of collected particles
 - to minimize particle deposition in the sampling tube
 - to collect the respirable size particles only
 - to collect samples suitable for direct analysis
- Theoretically, what is the minimum number of sound pressure level measurements needed to determine the sound power output from a non-directional noise source in a free field?
 - one
 - two
 - four
 - eight

12. What are too many levels of management, chronic and recurring internal problems, and numerous meetings attended by many people typically symptoms of?
1. poor communications
 2. lack of management training
 3. poor employee morale
 4. a flawed organizational structure

REFERENCES

ABIH examination questions are taken from a variety of sources in the literature to reflect the underlying purposes and principles of industrial hygiene as well as the current knowledge which is expected of the industrial hygienist. The Board suggests that candidates refer to the publications areas of the web sites of ACGIH (<http://www.acgih.org>), AIHA (<http://www.aiha.org>), and NIOSH (<http://cdc.gov/niosh/pubs.html>) and also to such publishers as CRC Press, Lewis Publishers, McGraw Hill, and John Wiley & Sons, among others for lists of available resources.

**Job Analysis – Certified Industrial Hygienist (CIH) Examination
November, 2008 Update (Effective October 1, 2009)**

The test specifications below identify three domains of performance and nine tasks. A domain is a major area of responsibility that defines the role of a CIH practitioner. A task is an activity performed within a performance domain. Knowledge and skills candidates should possess in order to perform the tasks are also included.

Domain I: Exposure Assessment Principles and Practice
50%

Task 1. Anticipate and recognize potential health hazards by studying environments, tasks, and people to identify risks associated with agents, products, and processes.

Knowledge of:

1. Basic sciences
2. Biological/chemical/physical/ergonomic hazards
3. Industry knowledge including raw materials, intermediates & final products
4. Process (unit operations) knowledge
5. Toxicology
6. Standards/Guidelines
7. Epidemiology
8. Environmental sciences
9. Public health (community health)
10. New process/chemical evaluation (pre OEL)

Skill in:

1. Extracting critical information from literature, standards, guidelines and other resources
2. Prioritizing hazards for evaluation
3. Anticipating exposure scenarios
4. Recognizing known potential hazards
5. Inventorying hazards
6. Surveying tasks, operations, and sites
7. Communicating with affected parties
8. Exposure reconstruction & forensic investigation

Task 2. Assess the relationship between exposure and the potential adverse health effects to determine if further action is warranted using recognized scientific principles, literature, and standards.

Knowledge of:

1. Basic sciences
2. Biological/chemical/physical/ergonomic hazards
3. Industry knowledge/work environments
4. Process (unit operations) knowledge
5. Toxicology
6. Epidemiology
7. Environmental sciences
8. Public health (community health)
9. Risk assessment
10. New process/chemical evaluation (pre OEL)

Skill in:

1. Understanding principles and concepts of toxicology (dose response, acute/chronic, latency, routes of entry)
2. Understanding principles and concepts of epidemiology (study design, cohorts)
3. Assessing source credibility
4. Communicating with affected parties

Task 3. Design and implement an exposure assessment strategy (qualitative and/or quantitative) to determine the extent and magnitude of exposure using relevant principles to ensure scientific validity.

Knowledge of:

1. Basic sciences
2. Biological/chemical/physical/ergonomic hazards
3. Industrial knowledge/work environments
4. Process (unit operations) knowledge
5. Sampling methods and instrumentation
6. Analytical chemistry
7. Study design
8. Standards/Guidelines
9. Statistics
10. Medical surveillance/monitoring technologies

Skill in:

1. Design exposure assessment strategies
2. Applying statistical principles to study design
3. Identifying appropriate exposed population(s)
4. Selecting appropriate sampling methods (instrumentation, analysis, strengths and limitations)
5. Understanding of industries and processes
6. Reviewing pertinent information (historical sampling data, existing controls, materials inventory, process review, work practices)
7. Understanding physical/chemical properties
8. Identifying routes of exposure
9. Implementing qualitative & quantitative exposure assessment strategies
10. Conducting investigations
11. Developing and managing projects
12. Conducting basic research
13. Knowing how to operate instruments, including calibration
14. Keeping good field records (chain of custody, sample labeling, field blanks)
15. Interacting with affected parties (interpersonal skills, human relations)
16. Identifying appropriate analytical methods

Task 4. Formulate conclusions, prioritize risks, and communicate findings and recommendations to stakeholders based on analysis and evaluation of data using standards, guidelines and professional judgment.

Knowledge of:

1. Basic sciences
2. Biological/chemical/physical/ergonomic hazards
3. Industry knowledge/work environments
4. Process knowledge
5. Toxicology
6. Analytical chemistry
7. Standards/Guidelines
8. Epidemiology
9. Risk communication
10. Statistics
11. Hierarchy of controls
12. Environmental sciences
13. Public Health (community health)

Skill in:

1. Analyzing sample data
2. Comparing sampling results to known standards/guidelines
3. Evaluating the quality of data (both new and old)

4. Evaluating potential risks of previously unrecognized hazards
5. Identifying potential risks of complex/complicated exposure scenarios
6. Developing & managing projects including risk management, evaluation of business impacts, sustainability and product stewardship
7. Characterizing risk (affected parties)
8. Communicating risk (oral, written)

Domain II: Control Selection, Implementation, and Validation
35%

Task 1. Assess and select options to eliminate or mitigate exposure using the hierarchy of controls and recognized scientific principles, literature, standards, and design and performance criteria.

Knowledge of:

1. Ventilation design (local exhaust, dilution, and HVAC)
2. Basic sciences, including physics, chemistry, biology, and aerosol sciences
3. Industrial processes and unit operations
4. Biomechanics, ergonomics, time and motion studies, and ergonomic intervention techniques
5. Principles of biohazard control
6. Hazardous material and remediation response
7. Principles of radiation and other physical energy protection (time, distance, shielding)
8. Principles of noise and noise abatement
9. PPE (protection factors, protective clothing, permeability/degradation, NRR)
10. Comprehensive understanding of toxicology
11. Physiology and anatomy, and routes of exposure (airborne, dermal, ingestion)
12. Physical properties and chemical incompatibility
13. Exposure guidelines
14. Work routines/work environments
15. Education and training
16. Work practices
17. Thermal stressor control
18. Hierarchy of controls
19. Community stressors
20. Cost impact for different control methods
21. Exposure guidelines
22. Impact of the environment and people on the controls selected

Skill in:

1. Designing controls
2. Conducting IH sampling, measurements and analyzing data
3. Measuring air flow parameters
4. Designing ventilation systems
5. Choosing the correct control method
6. Evaluating impact of unit operation
7. Understanding relevant physical properties of chemical and biological materials
8. Understanding the limitations of protective equipment to select the proper PPE
9. Understanding the strengths and limitations of PPE
10. Understanding the environment in which the control is to be used
11. Applying cost comparison
12. Understanding frequency, probability and severity of exposure
13. Understanding of protective factors (NRR, PF)
14. Understanding individual differences in workers
15. Interpreting building specifications

Task 2. Develop and implement appropriate control programs and techniques designed to eliminate or mitigate exposure.

Knowledge of:

1. Design of hazard controls (ventilation, noise abatement, radiation/physical energy, systems, PPE)

2. Requirements for writing performance specifications
3. Coordinating financial and staff resources
4. Procedures for training personnel in the use and application of control method
5. Industrial processes and unit operations
6. Hierarchy of controls
7. Training design & implementation, including adult learning
8. Communication strategies & tools
9. PPE selection & limitations
10. Reporting structures, roles & responsibilities

Skill in:

1. Designing control systems
2. Understanding unit operations
3. Applying project management skills
4. Performing training and education
5. Applying noise abatement technologies
6. Remediating biohazards and radiation
7. Remediating chemical hazards
8. Responding to chemical hazard emergencies
9. Applying proper ergonomic interventions
10. Reading and interpreting engineering instructions and specifications
11. Policy development
12. Developing & managing projects

Task 3. Validate the effectiveness of controls to eliminate or mitigate exposure using recognized scientific principles, literature, standards, and design and performance criteria.

Knowledge of:

1. Air sampling (chemical and biological agents)
2. Measurement techniques (ventilation, radiation, noise, thermal stress, vibration)
3. Basic science and statistics
4. Aerosol science
5. Principles of radiation
6. Microbiology
7. Ergonomic risk factors
8. Industrial process and unit operations
9. Application of exposure guidelines
10. Application of acceptable ventilation criteria
11. Hierarchy of controls
12. Control specifications
13. Equipment/technology used to validate control effectiveness
14. Auditing & quality assurance procedures
15. Basic research techniques

Skill in:

1. Using air sampling equipment
2. Making ventilation measurements
3. Making noise and vibration measurements
4. Making radiation measurements
5. Making thermal stress measurements
6. Comparing air sampling and measurement data to recognized criteria
7. Troubleshooting control technology
8. Reading and interpreting design drawings and specifications
9. Developing & managing projects

Domain III: Risk Management
15%

Task 1. Develop and implement programs that address health risks using recognized risk-based methodologies and appropriate scientific principles, literature, standards and effective communication strategies.

Knowledge of:

1. Comprehensive industrial hygiene program management principles, risk assessment principles, best practices, and regulatory requirements
2. Audit techniques
3. Communication strategies (concerning regulatory requirements, program needs)
4. Emergency planning and response procedures & resources

Skill in:

1. Communicating and interpreting regulatory requirements and communicating with regulatory agencies
2. Communicating industrial hygiene program components, including report writing & presentation
3. Managing program resources
4. Integrating industrial hygiene program needs into business plans
5. Prioritizing program needs
6. Identifying appropriate target audiences
7. Identifying appropriate program performance measurements
8. Risk communication
9. Program auditing
10. Understanding rationale for and application of occupational exposure limits (BEIs, TLVs)
11. Communicating environmental health stressors

Task 2. Evaluate programs designed to eliminate or mitigate exposure to assure effectiveness by comparing them to regulations, standards, guidelines, and professional practice.

Knowledge of:

1. Comprehensive industrial hygiene program management principles, best practices, and regulatory requirements
2. Communication strategies (concerning regulatory requirements, program needs)
3. Industrial hygiene program training needs
4. Audit techniques
5. Data management systems and record keeping requirements
6. Performance measurements/metrics

Skill in:

1. Communicating industrial hygiene program components, including report writing & presentation
2. Communicating regulatory requirements
3. Managing program resources
4. Prioritizing program needs
5. Training skills
6. Program auditing
7. Collecting performance data
8. Analyzing performance data
9. Performing program management analysis (gap analysis, benchmarking, etc.)

RUBRICS DEFINITIONS

Examination questions are categorized in the following rubrics (subject areas):

Air Sampling and Instrumentation

Selection, use and limitations of field air-sampling instruments, full-shift and grab samples, including direct-reading instruments. Also included are the set-up, calibration and use (including quality assurance practices) of air-sampling apparatus and direct-reading instruments, sampling strategy considerations and calculations related to sampling and calibration. Measurement of exposures to noise, ionizing radiation, nonionizing radiation, and thermal stressors are included in the rubrics dealing with those specific subject areas.

Analytical Chemistry

Laboratory analytical procedures for work place environmental samples and related calculations. Included are gas chromatography, infrared, visible and ultraviolet spectrophotometry, high performance liquid chromatography, mass spectroscopy, atomic absorption spectrophotometry, wet chemical methods, and microscopy and laboratory quality assurance and chain of custody.

Basic Science

General scientific concepts, chemistry, biochemistry, biology, anatomy and physiology, general physics and mathematics. Properties of flammable, combustible and reactive materials (compatibility) are included as are calculations such as those relative to gas laws, airborne concentrations, and unit-of-measure conversions and conditions of non-standard pressure.

Biohazards

Principles of sanitation, personal hygiene, the recognition, evaluation and control of biological agents or materials having the capacity to produce deleterious effects upon other biological organisms, particularly humans (virus, bacteria, fungi, molds, allergens, toxins, recombinant products, bloodborne pathogens, etc.) and infectious diseases that appear in workplaces including industry, agriculture, homes, offices and health care facilities.

Biostatistics & Epidemiology

Principles of epidemiology, techniques used to study the distribution of occupationally induced diseases and physiological conditions in workplaces and factors that influence their frequency. It includes concepts of prospective and retrospective studies, morbidity and mortality and animal experimental studies, data and distribution of data as well as basic biostatistics and statistical and non-statistical interpretation of data in the evaluation of hazards.

Community Exposure

Air pollution, air cleaning technology, ambient air quality considerations, emission source sampling, atmospheric dispersion of pollutants, ambient air monitoring, health and environmental effects of air pollutants and related calculations. Also included are other IH related environmental

subjects such as emergency planning and response, water pollution, hazardous waste, and environmental fate and transport.

Engineering Controls/Ventilation

Control of chemical and physical exposures through engineering measures such as local exhaust ventilation, dilution ventilation, isolation, containment and process change. Also included are mechanics of airflow, ventilation measurements, design principles and related calculations as well as in-plant recirculation air-cleaning technology.

Engineering control of ionizing and nonionizing radiation, thermal stressors, and noise and vibration sources including principles of isolation, enclosure, absorption and damping are included in the rubrics dealing with those specific subject areas.

Ergonomics

Application of principles from anthropometry, human factors engineering, biomechanics, work physiology, human anatomy, occupational medicine and facilities engineering to the design and organization of the workplace for the purpose of preventing injuries and illnesses.

Health Risk Analysis and Hazard Communication

Understanding of principles and requirements for the interpretation and use of guidelines for the assessment of health hazards, including American Conference of Governmental Industrial Hygienists (ACGIH) Threshold Limit Values (TLVs), Biological Exposure Indices (BEIs) and industrial ventilation guidelines, American National Standards Institute (ANSI) standards, American Society for Heating, Refrigeration, and Air Conditioning Engineers (ASHRAE) guidelines, American Society for Testing and Materials (ASTM) standards, and National Institute for Occupational Safety and Health (NIOSH) Criteria Documents and recommendations. Understanding of the risk reduction process including the hierarchy of controls, control banding and hazard communication and training of employees are included. Communication of recommendations by appropriate techniques to implement control actions is also included.

IH Program Management

Acquisition, allocation and control of resources to accomplish industrial hygiene anticipation, recognition, evaluation and control objectives in an effective and timely manner. Included are such topics as auditing, investigation methods, data management and integration, establishment of policy, planning, delegation of authority, accountability, risk communication, organizational structure, decision making and the ABIH Code of Ethics.

Noise

Health effects resulting from exposure to noise and vibration. Computations related to combining noise sources and octave band measurements are included as are audiometric testing programs. Includes exposure measurement, evaluation, and control.

Non-Engineering Controls

Personal protective equipment, including the principles governing selection, use and limitations of respirators and protective clothing. Included are respirator fit testing, breathing air specifications, glove permeability, eye protection and the use of administrative controls.

Radiation/Ionizing

Physical characteristics and health and biological effects associated with alpha, beta, gamma, neutron and x-radiation, including source characteristics. Includes exposure measurement, evaluation, and control.

Radiation/Nonionizing

Physical characteristics and health effects associated with electromagnetic fields, static electric and magnetic fields, lasers, radio frequency, microwaves, ultraviolet, visible, infrared radiation and illumination. Includes exposure measurement, evaluation, and control.

Thermal Stressors

Adverse health effects associated with heat and cold, symptoms of temperature-related health effects, exposure control techniques, and first-aid/medical response.

Toxicology

Health effects resulting from exposure to chemical substances including single agents and mixtures, and natural and synthetic agents. Included are symptomatology, pharmacokinetics, mode of action, additive, synergistic and antagonistic effects, routes of entry, absorption, metabolism, excretion, target organs, toxicity testing protocols and aerosol deposition and clearance in the respiratory tract. Also included are carcinogenic, mutagenic, teratogenic and reproductive hazards.

Work Environments and Industrial Processes

Included are the hazards associated with specific industrial or manufacturing processes. Topics include, but are not limited to confined space entry, spray-painting, welding, abrasive-blasting, vapor-degreasing, foundry operations, and hazardous waste site remediations, as well as general indoor environmental issues.

EQUATION SHEET

The following pages of equations and conversions will be available on the computer on which the exams are given for use during the examinations. The following plates from the 24th Edition of the ACGIH "Ventilation Manual" will also be available on the computer for use during the examinations: 3-11, 3-16, 5-15, 5-16, 5-17 and 5-18.

USEFUL EQUATIONS FOR THE ABIH EXAMINATIONS

This list of equations is offered as assistance in taking the ABIH examinations. No assurance is given that this list is complete or that the use of this list will assure the successful completion of any examination. The variables used are the same as found in the reference source for the equation. No attempt has been made to standardize variables.

VENTILATION

$$Q = VA \quad V_1 A_1 = V_2 A_2 \quad TP = VP + SP \quad SP_1 + VP_1 = SP_2 + VP_2 + h_L \quad V = 4005\sqrt{VP} \quad |SP_h| = VP + h_e$$

$$h_e = \frac{1 - C_e^2}{C_e^2} VP \quad h_e = F_h x VP_d \quad C_e = \sqrt{\frac{VP}{|SP_h|}} \quad VP_{ave} = \left(\frac{\sqrt{VP_1} + \sqrt{VP_2} + \dots + \sqrt{VP_n}}{n} \right)^2 \quad VP_r = \left(\frac{Q_1}{Q_3} \right) VP_1 + \left(\frac{Q_2}{Q_3} \right) VP_2$$

$$V = 1096 \sqrt{\frac{VP}{\rho}} \quad Q = 4005 C_e A \sqrt{|SP_h|} \quad Q = 4005 A \sqrt{\frac{SP_h}{df(1 + F_h)}} \quad Q = 1096 A \sqrt{\frac{SP_h}{\rho(1 + F_h)}} \quad Q_{cor} = Q_{design} \sqrt{\frac{SP_{gov}}{SP_{duct}}}$$

$$Q' = \frac{Q}{K} \quad t_2 - t_1 = -\frac{V_r}{Q'} \ln \left(\frac{C_2}{C_1} \right) \quad \ln \left(\frac{G - Q' C_2}{G - Q' C_1} \right) = -\frac{Q'(t_2 - t_1)}{V_{room}} \quad C = \left(\frac{G}{Q'} x 10^6 \right) + C_{supply}$$

$$N_{changes} = \frac{60Q}{V_{room}} \quad C = \frac{G}{Q'} (1 - e^{-Nt/60}) x 10^6 \quad C = C_0 e^{-tN_{changes}} \quad Q = \frac{(403)(s.g.)(ER)(K)(10^6)}{(m.w.)(C)} \quad C = \frac{gx24.45x10^6}{MWxV}$$

$$Q_2 = Q_1 \left(\frac{Size_2}{Size_1} \right)^3 \left(\frac{RPM_2}{RPM_1} \right) \quad P_2 = P_1 \left(\frac{Size_2}{Size_1} \right)^2 \left(\frac{RPM_2}{RPM_1} \right)^2 \quad PWR_2 = PWR_1 \left(\frac{Size_2}{Size_1} \right)^5 \left(\frac{RPM_2}{RPM_1} \right)^3$$

$$FSP = SP_{out} - SP_{in} - VP_{in} \quad FTP = TP_{out} - TP_{in}$$

NOISE

$$SPL = 20 \left(\log \frac{P}{P_0} \right) \quad SPL = 10 \left(\log \frac{I}{I_0} \right) \quad SPL_2 = SPL_1 + 20 \log \left(\frac{d_1}{d_2} \right)$$

$$SPL_f = 10 \log \sum 10^{\frac{SPL}{10}} \quad SPL_f = SPL_I + 10 \log(n) \quad L_w = 10 \log \left(\frac{W}{W_0} \right) \quad W_0 = 10^{-12} \text{ watts}$$

$$L_{Total} = L_1 + 10 \log \left(10^{\frac{L_2 - L_1}{10}} + 1 \right) \quad L_{eq} = 10 \log \left(\frac{1}{T} \sum_{i=1}^N \left(10^{\frac{L_i}{10}} t_i \right) \right) \quad L_{PT} = 10 \log \left(\sum_{i=1}^N 10^{\frac{L_{Pi}}{10}} \right) \quad TL = 10 \log \left(\frac{E_i}{E_t} \right)$$

$$L_p = L_w - 20 \log_{10} r - 0.5 + DI + T \quad DI = 10 \log_{10} Q \quad \%D = 100 \left(\frac{C_1}{T_1} + \frac{C_2}{T_2} + \dots + \frac{C_i}{T_i} \right)$$

$$T = 8/2^{(level-85)/3} \quad TWA_{eq} = 10 \log \left(\frac{\%D}{100} \right) + 85dBA \quad TWA = 16.61 \log \left(\frac{\%D}{100} \right) + 90dBA \quad f = \frac{(N)(RPM)}{60}$$

$$f = \frac{c}{\lambda} \quad f_2 = 2f_1 \quad f_c = \sqrt{f_1 f_2} \quad f_2 = \sqrt{2} f_1 \quad f_2 = \sqrt[3]{2} f_1$$

USEFUL EQUATIONS FOR THE ABIH EXAMINATIONS

This list of equations is offered as assistance in taking the ABIH examinations. No assurance is given that this list is complete or that the use of this list will assure the successful completion of any examination. The variables used are the same as found in the reference source for the equation. No attempt has been made to standardize variables.

GENERAL SCIENCES, STATISTICS, STANDARDS

$$ppm = \frac{V_{contam}}{V_{air}} \times 10^6 \quad ppm = \frac{P_v}{P_{atm}} \times 10^6 \quad ppm = \frac{mg / m^3 \times 24.45}{m.w.} \quad \frac{P_1 V_1}{nRT_1} = \frac{P_2 V_2}{nRT_2} \quad V_{TS} = \frac{gd_p^2 (\rho_p - \rho_a)}{18\eta}$$

$$R_e = \frac{\rho dv}{\eta} \quad \log \frac{I_o}{I} = abc \quad pH = -\log_{10}[H^+] \quad K_a = \frac{[H^+]x[A^-]}{[HA]} \quad K_b = \frac{[BH^+]x[OH^-]}{[B]}$$

$$P_{total} = X_1 P_1 + X_2 P_2 + \dots + X_i P_i \quad \text{vapor/hazard ratio} = \frac{\text{sat. concentration}}{\text{exposure guideline}} \quad TLV_{mix} = \frac{C_1}{TLV_1} + \frac{C_2}{TLV_2} + \dots + \frac{C_n}{TLV_n}$$

$$TLV_{mix} = \frac{1}{\frac{F_1}{TLV_1} + \frac{F_2}{TLV_2} + \dots + \frac{F_n}{TLV_n}} \quad RF = \frac{8}{h} x \frac{24-h}{16} \quad RF = \frac{40}{h_w} x \frac{168-h_w}{128} \quad C_{asb} = \frac{(C_s - C_b)A_c}{1000A_f V_s} \quad C_{asb} = \frac{EA_c}{1000V_s}$$

$$E_{fiber\ density} = \frac{\frac{f}{N_f} - \frac{B}{N_b}}{A_f} \quad d = \frac{0.61\lambda}{\eta \sin \alpha} \quad \bar{X} = \frac{X_1 + X_2 + \dots + X_n}{n} \quad SD = \sqrt{\frac{\sum (x - \bar{x})^2}{n-1}} \quad GM = \sqrt[n]{(x_1)(x_2)\dots(x_n)}$$

$$GM = 10^{\frac{\sum(\log x)}{n}} \quad GSD = \frac{84.13\% \text{ tile value}}{50\% \text{ tile value}} \quad GSD = \frac{50\% \text{ tile value}}{15.87\% \text{ tile value}} \quad SAE = 1.645 CV_{total} \quad CV = \frac{SD}{\bar{X}}$$

$$E_c = \sqrt{E_1^2 + E_2^2 + \dots + E_n^2} \quad t = \frac{\bar{x}_1 - \bar{x}_2}{SD_{pooled} \sqrt{\frac{1}{n_1} + \frac{1}{n_2}}} \quad SD_{pooled} = \sqrt{\frac{(n_1 - 1)SD_1^2 + (n_2 - 1)SD_2^2}{n_1 + n_2 - 2}}$$

$$LCL = \frac{C_A}{PEL} - \frac{SAE \sqrt{T_1^2 C_1^2 + T_2^2 C_2^2 + \dots + T_n^2 C_n^2}}{PEL(T_1 + T_2 + \dots + T_n)} \quad 95\% \text{ Conf} = \bar{X} \pm 1.645 \frac{SD}{\sqrt{n}} \quad 95\% \text{ Conf} = \bar{X} \pm 1.96 \frac{SD}{\sqrt{n}}$$

HEAT STRESS

$$WBGT = 0.7t_{nwb} + 0.2t_g + 0.1t_{db} \quad WBGT = 0.7t_{nwb} + 0.3t_g \quad \Delta S = (M - W) \pm C \pm R - E \quad R = 15(t_w - 95)$$

$$C = 0.65v^{0.6}(t_a - 95) \quad E_{max} = 2.4v^{0.6}(42 - vp_w) \quad cfm = \frac{\text{Total Sensible Heat (BTU / hr)}}{1.08(\Delta T)} \quad HSI = \frac{E_{req}}{E_{max}} \times 100$$

USEFUL EQUATIONS FOR THE ABIH EXAMINATIONS

This list of equations is offered as assistance in taking the ABIH examinations. No assurance is given that this list is complete or that the use of this list will assure the successful completion of any examination. The variables used are the same as found in the reference source for the equation. No attempt has been made to standardize variables.

RADIATION

$$I_2 = I_1 \left(\frac{d_1}{d_2} \right)^2 \quad \text{Rem} = (\text{RAD})(QF) \quad D = \frac{\Gamma A}{d^2} \quad A = A_i (0.5)^{\frac{t}{T_{1/2}}} \quad A_i = \frac{0.693}{T_{1/2}} N_i \quad A = A_i e^{\frac{-0.693t}{T_{1/2}}}$$

$$I = (1/2)^A I_0 \quad I = (1/10)^B I_0 \quad I_2 = \frac{I_1}{\frac{X}{2^{HVL}}} \quad I_2 = \frac{I_1}{10^{\frac{TVL}{X}}} \quad X = 3.32 \log \left(\frac{I_1}{I_2} \right) (\text{HVL}) \quad I = I_0 B e^{-\mu x}$$

$$\frac{1}{T_{1/2\text{eff}}} = \frac{1}{T_{1/2\text{rad}}} + \frac{1}{T_{1/2\text{bio}}} \quad T_{1/2\text{eff}} = \frac{(T_{1/2\text{rad}})(T_{1/2\text{bio}})}{T_{1/2\text{rad}} + T_{1/2\text{bio}}} \quad PD = \frac{E^2}{3770} \quad PD = 37.7 H^2 \quad W = \frac{4P}{A} \quad r = \left(\frac{PG}{4\pi EL} \right)^{1/2}$$

$$B_r = \sqrt{B_x^2 + B_y^2 + B_z^2} \quad r_{\text{NHZ}} = \frac{1}{\phi} \left(\frac{4\Phi}{\pi EL} - a^2 \right)^{1/2} \quad r_{\text{NHZ}} = \frac{f_0}{b_0} \left(\frac{4\Phi}{\pi EL} \right)^{1/2} \quad r_{\text{NHZ}} = \left(\frac{\rho\Phi \cos \theta}{\pi EL} \right)^{1/2} \quad D_s = \frac{1}{\phi} \left(\frac{4\Phi}{\pi TL} - a^2 \right)^{1/2}$$

$$\text{spatial ave} = \left(\frac{\sum_{i=1}^N FS_i^2}{N} \right)^{1/2} \quad t = \frac{0.003J / \text{cm}^2}{E_{\text{eff}}} \quad t = \frac{EL}{ML} \times 0.1h \quad O.D. = \log \frac{I_0}{I} \quad D_L = \sqrt{a^2 + \phi^2 r^2}$$

$$I_2 = I_1 x (\text{magnification})^2 \quad G = 10^{g/10}$$

CONSTANTS AND CONVERSIONS

$$^{\circ}\text{F} = 9/5(^{\circ}\text{C}) + 32 \quad ^{\circ}\text{R} = ^{\circ}\text{F} + 460 \quad \text{K} = ^{\circ}\text{C} + 273.15 \quad \text{molar volume at } 25^{\circ}\text{C, } 1 \text{ atm} = 24.45\text{L} \quad 1 \text{ ft}^3 = 28.32\text{L}$$

$$1 \text{ ft}^3 = 7.481 \text{ U.S. gal} \quad 1\text{L} = 1.0566 \text{ qt} \quad 1 \text{ inch} = 2.54 \text{ cm} \quad 1 \text{ lb} = 453.6 \text{ gm} \quad 1 \text{ gram} = 15.43 \text{ grains}$$

$$1 \text{ atm} = 14.7 \text{ psi} = 760 \text{ mm Hg} = 29.92 \text{ in Hg} = 33.93 \text{ ft water} = 1013.25 \text{ mbar} = 101,325 \text{ pascals}$$

$$1 \text{ Currie} = 3.7 \times 10^{10} \text{ disint/sec (Becquerel)} = 2.2 \times 10^{12} \text{ dpm} \quad 1 \text{ Gray} = 100 \text{ Rad} \quad 1 \text{ Sievert} = 100 \text{ Rem}$$

$$1 \text{ Tesla} = 10,000 \text{ Gauss} \quad 1 \text{ BTU} = 1054.8 \text{ joules} = 0.293 \text{ watt hr} \quad 1 \text{ cal} = 4.184 \text{ joules}$$

$$\text{speed of sound in air at } 20^{\circ}\text{C} = 1130 \text{ ft/sec} \quad \text{speed of light} = 3 \times 10^8 \text{ m/sec}$$

$$\text{Planck's constant} = 6.626 \times 10^{-27} \text{ erg sec} \quad \text{Avogadro's number} = 6.024 \times 10^{23}$$

$$\text{gas constant, } R = 8.314 \text{ J/mole K} = 0.082 \text{ L atm/mole K}$$

$$g = 981 \text{ cm/sec}^2 = 32 \text{ ft/sec}^2 \quad A_c = 385 \text{ mm}^2 \text{ for } 25 \text{ mm filter} \quad \text{density of air} = 1.29 \text{ g/L at } 1 \text{ atm, } 0^{\circ}\text{C}$$

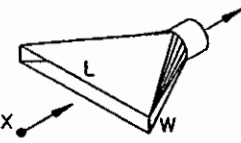
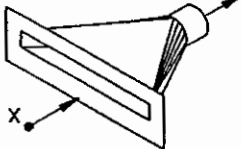
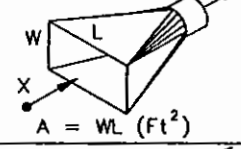
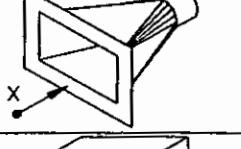
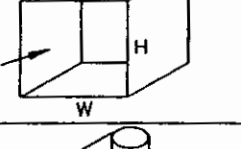
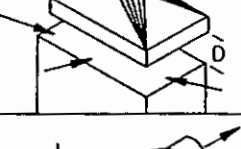
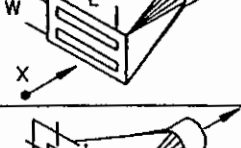
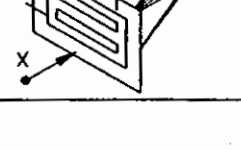
HOOD TYPE	DESCRIPTION	ASPECT RATIO, W/L	AIR FLOW
	SLOT	0.2 OR LESS	$Q = 3.7 LVX$
	FLANGED SLOT	0.2 OR LESS	$Q = 2.6 LVX$
	PLAIN OPENING	0.2 OR GREATER AND ROUND	$Q = V(10X^2 + A)$
	FLANGED OPENING	0.2 OR GREATER AND ROUND	$Q = 0.75V(10X^2 + A)$
	BOOTH	TO SUIT WORK	$Q = VA = VWH$
	CANOPY	TO SUIT WORK	$Q = 1.4 PVD$ SEE FIG. VS-99-03 P = PERIMETER D = HEIGHT ABOVE WORK
	PLAIN MULTIPLE SLOT OPENING 2 OR MORE SLOTS	0.2 OR GREATER	$Q = V(10X^2 + A)$
	FLANGED MULTIPLE SLOT OPENING 2 OR MORE SLOTS	0.2 OR GREATER	$Q = 0.75V(10X^2 + A)$

AMERICAN CONFERENCE
OF GOVERNMENTAL
INDUSTRIAL HYGIENISTS

HOOD TYPES

DATE 4-96

FIGURE 3-11

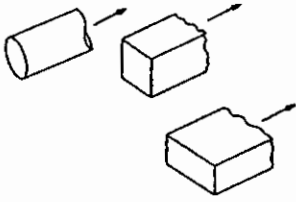
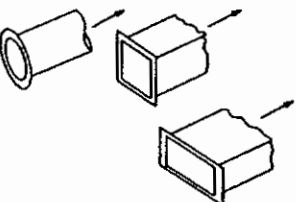
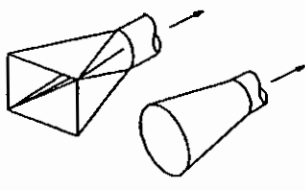
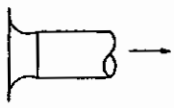
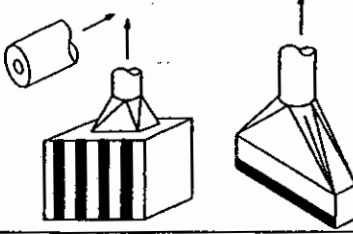
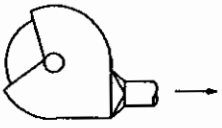
HOOD TYPE	DESCRIPTION	HOOD ENTRY LOSS (F _L) COEFFICIENT
	PLAIN OPENING	0.93
	FLANGED OPENING	0.49
	TAPER OR CONE HOOD	SEE CHAPTER 10
	BELL MOUTH INLET	0.04
	ORIFICE	SEE CHAPTER 10
	TYPICAL GRINDING HOOD	(STRAIGHT TAKEOFF) 0.65
		(TAPERED TAKEOFF) 0.40
AMERICAN CONFERENCE OF GOVERNMENTAL INDUSTRIAL HYGIENISTS		<p style="text-align: center;"><i>HOOD LOSS COEFFICIENTS</i></p> <p>DATE <i>4-96</i> FIGURE <i>3-16</i></p>

From American Conference of Governmental Industrial Hygienists: Industrial Ventilation: A Manual of Recommended Practice, 24th Edition; Copyright 2001, Cincinnati, Ohio. Reprinted with permission.



$h_e = 0.93 VP_d$
PLAIN DUCT END



$h_e = 0.49 VP_d$
FLANGED DUCT END

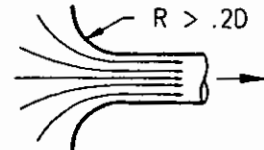

$h_e = 0.04 VP_d$
BELLMOUTH ENTRY

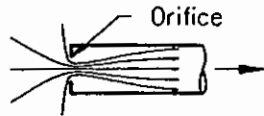

$h_e = 1.78 VP_{Orifice}$
SHARP-EDGED
ORIFICE

* $h_e = F_h VP_d$ See 3.5.1

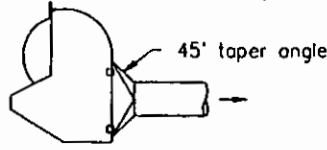

$h_e = 0.4 VP_d$ (topered take-off)
 $h_e = 0.65 VP_d$ (no toper)
STANDARD GRINDER HOOD

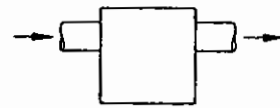

$h_e = 1.5 VP_d$
TRAP OR SETTLING CHAMBER

TAPERED HOODS

Flanged or unflanged; round, square or rectangular. θ is the major angle on rectangular hoods.

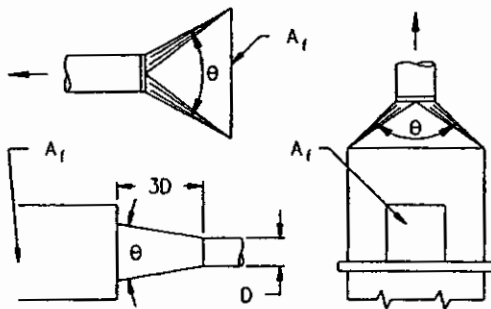

Face area (A_f) at least 2 times the duct area.

θ	ENTRY LOSS (h_e)	
	ROUND	RECTANGULAR
15°	0.15 VP	0.25 VP
30°	0.08 VP	0.16 VP
45°	0.06 VP	0.15 VP
60°	0.08 VP	0.17 VP
90°	0.15 VP	0.25 VP
120°	0.26 VP	0.35 VP
150°	0.40 VP	0.48 VP
180°	0.50 VP	0.50 VP

VP = Duct VP = VP_d
Note: 180° values represent round ducts butted into back of booth or hood without a rectangular to round transition.

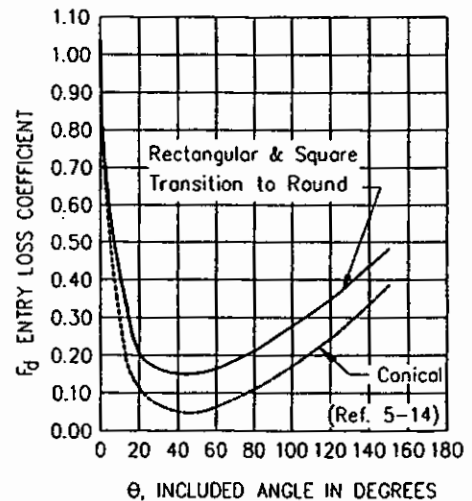

COMPOUND HOODS

A compound hood, such as the slot/plenum shown to the right, would have 2 losses, one through the slot and the other through the transition into the duct.

The slot entry loss coefficient, F_s , would have a value typically in the range of 1.00 to 1.78 (see Chapters 3 and 10).

The duct entry loss coefficient is given by the above data for tapered hoods.

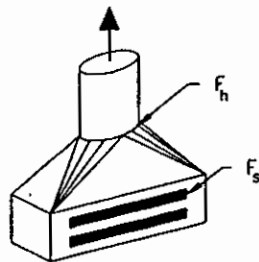

$$h_e = F_s VP_s + F_h VP_d$$

MISCELLANEOUS VALUES

HOOD	ENTRY LOSS COEFFICIENT F_h
Abrasive blast chamber	1.0
Abrasive blast elevator	2.3
Abrasive separator	2.3
Elevators (enclosures)	0.69
Flanged pipe plus close elbow	0.8
Plain pipe plus close elbow	1.60

AMERICAN CONFERENCE
OF GOVERNMENTAL
INDUSTRIAL HYGIENISTS

HOOD ENTRY
LOSS COEFFICIENTS

DATE 1-95

FIGURE 5-15

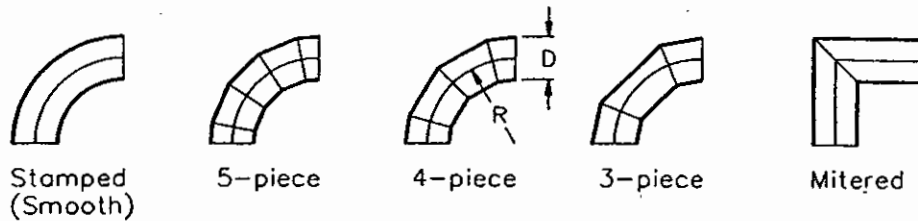

	R/D					
	0.5	0.75	1.00	1.50	2.00	2.50
Stamped	0.71	0.33	0.22	0.15	0.13	0.12
5-piece	—	0.46	0.33	0.24	0.19	0.17*
4-piece	—	0.50	0.37	0.27	0.24	0.23*
3-piece	0.90	0.54	0.42	0.34	0.33	0.33*

* extrapolated from published data

OTHER ELBOW LOSS COEFFICIENTS

Mitered, no vanes 1.2
 Mitered, turning vanes 0.6
 Flatback (R/D = 2.5) 0.05 (see Figure 5-23)

NOTE: Loss factors are assumed to be for elbows of "zero length." Friction losses should be included to the intersection of centerlines.

ROUND ELBOW LOSS COEFFICIENTS

(Ref. 5.13)

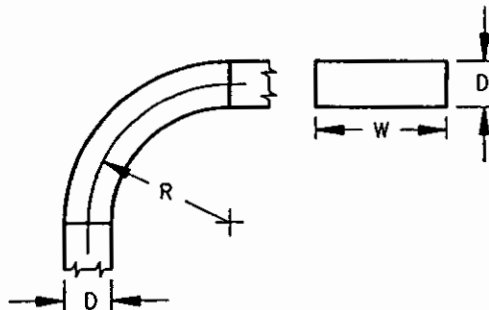

R/D	Aspect Ratio, W/D					
	0.25	0.5	1.0	2.0	3.0	4.0
0.0 (Mitered)	1.50	1.32	1.15	1.04	0.92	0.86
0.5	1.36	1.21	1.05	0.95	0.84	0.79
1.0	0.45	0.28	0.21	0.21	0.20	0.19
1.5	0.28	0.18	0.13	0.13	0.12	0.12
2.0	0.24	0.15	0.11	0.11	0.10	0.10
3.0	0.24	0.15	0.11	0.11	0.10	0.10

SQUARE & RECTANGULAR ELBOW LOSS COEFFICIENTS

AMERICAN CONFERENCE
 OF GOVERNMENTAL
 INDUSTRIAL HYGIENISTS

DUCT DESIGN DATA
 ELBOW LOSSES

DATE 1-95 FIGURE 5-16

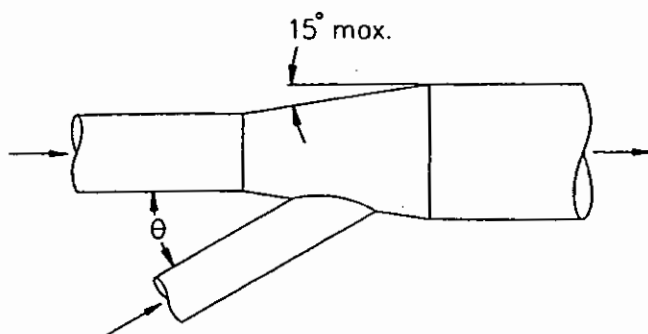

Note: Branch entry loss assumed to occur in branch and is so calculated.

Do not include an enlargement regain calculation for branch entry enlargements.

Angle θ Degrees	Loss Fraction of VP in Branch
10	0.06
15	0.09
20	0.12
25	0.15
30	0.18
35	0.21
40	0.25
45	0.28
50	0.32
60	0.44
90	1.00

BRANCH ENTRY LOSSES

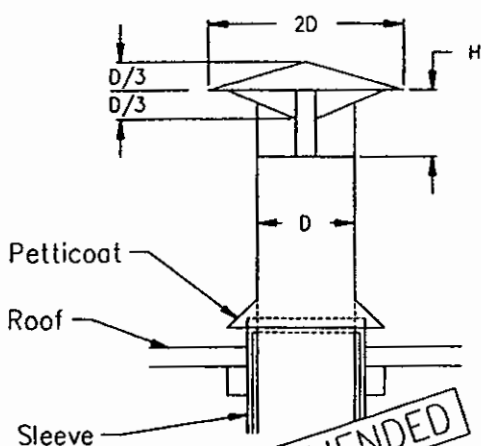

H, No. of Diameters	Loss Fraction of VP
1.0 D	0.10
0.75 D	0.18
0.70 D	0.22
0.65 D	0.30
0.60 D	0.41
0.55 D	0.56
0.50 D	0.73
0.45 D	1.0

WEATHER CAP LOSSES

See Fig. 5-30

AMERICAN CONFERENCE
OF GOVERNMENTAL
INDUSTRIAL HYGIENISTS

DUCT DESIGN DATA

DATE 1-95

FIGURE 5-17

STATIC PRESSURE REGAINS FOR EXPANSIONS

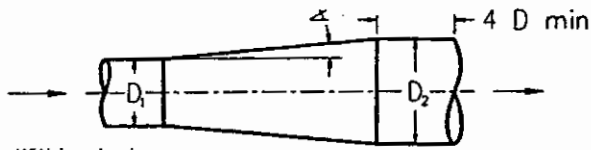

Within duct

Regain (R), fraction of VP difference					
Taper angle degrees	Diameter ratios D_2/D_1				
	1.25:1	1.5:1	1.75:1	2:1	2.5:1
3 1/2	0.92	0.88	0.84	0.81	0.75
5	0.88	0.84	0.80	0.76	0.68
10	0.85	0.76	0.70	0.63	0.53
15	0.83	0.70	0.62	0.55	0.43
20	0.81	0.67	0.57	0.48	0.43
25	0.80	0.65	0.53	0.44	0.28
30	0.79	0.63	0.51	0.41	0.25
Abrupt 90	0.77	0.62	0.50	0.40	0.25

Where: $SP_2 = SP_1 + R(VP_1 - VP_2)$

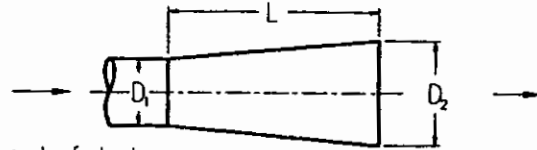

At end of duct

Regain (R), fraction of inlet VP						
Taper length to inlet diam L/D	Diameter ratios D_2/D_1					
	1.2:1	1.3:1	1.4:1	1.5:1	1.6:1	1.7:1
1.0:1	0.37	0.39	0.38	0.35	0.31	0.27
1.5:1	0.39	0.46	0.47	0.46	0.44	0.41
2.0:1	0.42	0.49	0.52	0.52	0.51	0.49
3.0:1	0.44	0.52	0.57	0.59	0.60	0.59
4.0:1	0.45	0.55	0.60	0.63	0.63	0.64
5.0:1	0.47	0.56	0.62	0.65	0.66	0.68
7.5:1	0.48	0.58	0.64	0.68	0.70	0.72

Where: $SP_1 = SP_2 - R(VP_1)$

When $SP_2 = 0$ (atmosphere) SP_1 will be (-)

The regain (R) will only be 70% of value shown above when expansion follows a disturbance or elbow (including a fan) by less than 5 duct diameters.

STATIC PRESSURE LOSSES FOR CONTRACTIONS

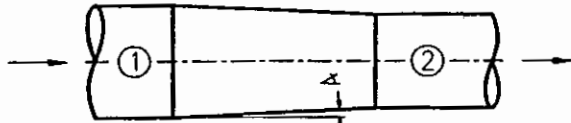

Tapered contraction
 $SP_2 = SP_1 - (VP_2 - VP_1) - L(VP_2 - VP_1)$

Taper angle degrees	L(loss)
5	0.05
10	0.06
15	0.08
20	0.10
25	0.11
30	0.13
45	0.20
60	0.30
over 60	Abrupt contraction

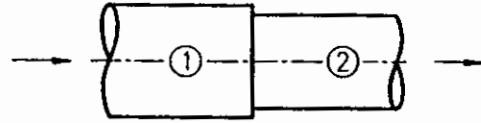

Abrupt contraction
 $SP_2 = SP_1 - (VP_2 - VP_1) - K(VP_2)$

Ratio A_2/A_1	K
0.1	0.48
0.2	0.46
0.3	0.42
0.4	0.37
0.4	0.32
0.6	0.26
0.7	0.20

$A =$ duct area, ft^2

Note:

In calculating SP for expansion or contraction use algebraic signs: VP is (+), and usually SP is (+) in discharge duct from fan, and SP is (-) in inlet duct to fan.

AMERICAN CONFERENCE
OF GOVERNMENTAL
INDUSTRIAL HYGIENISTS

DUCT DESIGN DATA

DATE

1-95

FIGURE

5-18