



Candidate Handbook

Certified Industrial Hygienist[®] – CIH[®]

6015 W. St. Joseph, Suite 102
Lansing, MI 48917
(517) 321-2638 Phone
(517) 321-4624 Fax
www.abih.org
abih@abih.org

Table of Contents

Application Requirements

QUALIFICATIONS AND EVALUATION	1
ACADEMIC REQUIREMENTS	1
INDUSTRIAL HYGIENE COURSEWORK	3
EXPERIENCE REQUIREMENTS	4
REFERENCES	5
TEST ACCOMMODATIONS	6
REAPPLICANTS	6
APPLICATION and REAPPLICATION DEADLINES	7
FEES	7
GENERAL	8
EXAMINATION PROCEDURES	8
SCORING OF EXAMINATIONS	11
NOTIFICATION	11
EXAMINATION PREPARATION	11
SAMPLE QUESTIONS	12
REFERENCES	14
CIH® EXAM BLUEPRINT	15
RUBRICS DEFINITIONS	21
EQUATION SHEET	23

APPLICATION REQUIREMENTS

QUALIFICATIONS AND EVALUATION

To qualify for admission to the ABIH examinations, an applicant must comply with all regulations of the Board that are in effect at the time the application is filed. An applicant must:

- Meet academic requirements/IH coursework
- Meet a professional industrial hygiene experience requirement supported by references
- Be in the current practice of industrial hygiene
- Agree to adhere to the ABIH Code of Ethics and to be governed by the ABIH Ethics Case Procedures

Deadline

All application materials, including transcripts, references, and educational coursework (including ethics) must be postmarked by February 1 for the Spring examination, or August 1 for the Fall examination.

Evaluation

ABIH will evaluate all applicants using the criteria set for CIH eligibility and will not discriminate on the basis of race, creed, national origin, religion, age, disability, political affiliation, sex, sexual orientation, or marital, parental, military, or any other legally protected status.

Supplemental information may be requested from the applicant, when initial review of an application (or reapplication) indicates that pertinent information is unclear. In that case, review of the application or reapplication will not proceed until the requested information is received.

A Director of the Board is not authorized to give an opinion to any applicant as to his/her eligibility, either before or after an application is filed.

Confidentiality

Original applications and supporting documentation are treated by ABIH Board of Directors and staff as confidential information. As noted in the ABIH Privacy Policy, all reasonable precautions are taken to prevent unauthorized access to individual information. ABIH does not disclose personal information obtained from an applicant to third parties, except when authorized by the applicant or if necessary to complete the process – for example, arranging for an examinee to sit for the exam.

Record Retention

In accordance with the ABIH record-retention program, files that have been inactive for three years will be destroyed. Prior to destroying a file, the staff will attempt to notify the applicant using his or her last known address.

ACADEMIC REQUIREMENTS

The applicant must have a bachelor's degree in biology, chemistry, physics, or engineering from a regionally accredited college or university, or from another college that is acceptable to the Board. An ABET-accredited program in industrial hygiene or safety also is accepted.

The Board will consider, and may accept, any other bachelor's degree from an acceptable college or university, provided that the degree is based upon appropriate coursework and represents at least 60 semester hours of creditable subjects, with at least 15 of those hours at the upper level (junior, senior, or graduate level). Creditable subjects are undergraduate or graduate level courses in science, mathematics, engineering and science-based technology.

Unacceptable Academic Degrees or Credit

Remedies. An applicant who is found to have an unacceptable bachelor's degree may remedy that degree with additional academic science coursework from an acceptable college or university, or by completion of an acceptable cognate graduate degree.

Nonrelevant Courses. Academic credit granted by a college or university based upon an applicant's activities unrelated to appropriate coursework will not be accepted by ABIH. Examples are the completion of:

- the Graduate Record Examination (GRE),
- College Level Examination Program (CLEP) examinations,
- DANTES Subject Standardized Tests (DSSTs),
- and similar equivalency credits granted by an institution for work/life experience.

These are not considered educational courses that satisfy the academic certification eligibility requirements.

The social sciences are not considered to be qualifying sciences. Evaluation of the science content of a bachelor's degree will be made from the official transcripts. When evaluators need further information about the content of a degree, such as course descriptions or content, the applicant will be requested to provide the information. Review of the degree will not proceed until the information is received.

U.S. and Canadian Degrees

Official transcripts must be submitted for each degree. An "official" transcript is one sent directly to ABIH by the college or university. Alternatively, the applicant may submit official transcripts if they are in a sealed envelope with the registrar's stamp across the seal. When a degree includes credits that were transferred from another college or university, official transcripts for those course credits must be sent upon request.

The Board will consider a U.S. college or university to be acceptable when it holds institutional accreditation from one of the six Regional Accrediting Bodies or the Distance Education and Training Council, which are recognized by the Council for Higher Education Accreditation (CHEA) and the U.S. Department of Education. The degree must be awarded during the time for which the institutional accreditation was issued. A Canadian college or university will be considered acceptable if it is recognized under applicable provincial standards, depending on where the school is located. Or, it may hold specialized program accreditation as noted by membership in the Association of Universities and Colleges of Canada (AUCC).

If an applicant has several degrees and at least one of them is from the United States or Canada, a transcript evaluation may not be required for the international degree(s). However, in some cases, a report may also be required for a Canadian degree. Please contact the office (abih@abih.org) for advice.

International Degrees

A degree from a college or university that is located outside the United States or Canada will be considered for acceptability based on the institution's accreditation status in the education system that has jurisdiction. Applicants with international degrees will be required to submit their transcript(s) for a credential evaluation.

A member of the National Association of Credential Evaluation Services, Inc. (<http://www.naces.org/members.htm>) or a member of the Association of International Credential Evaluators (<http://www.aice-eval.org>) must be used to prepare a credential evaluation report. Applicants should request that the report be forwarded to ABIH.

If the applicant's degree is in biology, chemistry, engineering, or physics, a General/Document-by-Document report must be provided. Any other degree requires a Comprehensive/Course-by-Course report.

INDUSTRIAL HYGIENE COURSEWORK

The Board requires applicants to document completion of 180 academic contact hours or 240 continuing education contact hours of specific industrial hygiene courses.

At least half of the required coursework (90 academic or 120 continuing education contact hours) must cover the broad subjects of industrial hygiene **toxicology, fundamentals** of industrial hygiene, and **measurements** and **controls**. Conference related professional development courses can be counted but attendance at a conference cannot be counted as a training course.

- Acceptable toxicology courses will cover the essential aspects of toxicology (adverse effects of chemicals on living systems), with an emphasis on humans. Topics covered are likely to include dose response relationships; absorption, distribution, metabolism, and excretion of toxic substances in the body; biotransformation; organ systems; and chemical carcinogenesis and mutagenesis.
- Fundamentals courses are likely to address recognizing hazards/stressors found in the work environment. Included are chemical, physical (noise, radiation, thermal), biological, and ergonomic stressors.
- Measurement courses and control (engineering, substitution, administrative, PPE) courses will address the same four broad stressor categories as fundamentals, above.

The remaining coursework may be in industrial hygiene subjects that are narrower in scope (e.g., asbestos, lead, mold, and confined space entry). *Regulatory refresher courses can be counted only once.*

Stand-alone industrial hygiene related specialty exams for other professional certifications as well as many other non-certification exams used for licensing and registration can be used as narrow scope continuing education contact hours. Stand-alone exams are those offered independently from any other educational activities such as classes or workshops.

- The exam must be at least 1 hour in duration and must align with one of the IH Rubrics or the IH Job Analysis.
- One continuing education contact hour can be counted for each hour allotted to the exam.
- The exam must be offered by the organization responsible for overseeing exam development and administration.
- Documentation of successful completion of the exam and its duration must be provided to claim the equivalent continuing education contact hours.

The IH coursework requirement can be satisfied if the necessary contact hours were completed as part of the applicant's academic degree.

If additional coursework is taken to meet this requirement, the applicant may submit academic courses, continuing education courses, or a combination, as follows:

- One semester hour equals 15 academic contact hours or 20 continuing education contact hours.
- One quarter hour equals 10 academic contact hours or 13 continuing education contact hours.
- One CEU equals 10 continuing education contact hours.

For documentation of continuing education contact hours, copies of certificates need to be sent with the application. **If the number of contact hours or CEUs is not on the certificate, the applicant must include an agenda.**

Ethics Requirement

New applicants must document that they have completed at least two contact hours of coursework in ethics. Acceptable ethics courses include academic courses dealing with ethics, company training on business conduct, or other ethics related subjects, or continuing education courses that present ethics topics.

This ethics coursework will count as part of the current industrial hygiene coursework requirement. Credit for ethics is capped at five contact hours.

EXPERIENCE REQUIREMENTS

Professional Level Experience

To be eligible for the examination, an applicant must have four years of employment in the professional practice of industrial hygiene and be currently engaged in active practice. To be recognized as “**professional level**” work acceptable to the Board, the experience must meet the following four criteria:

- **Independence of actions.** This relates to the amount of planning, self-direction, decision-making and autonomy involved in the work experience.
- **Depth of work.** This relates to the extent to which work experience requires data-gathering, analysis, and interpretation.
- **Level of interaction.** This relates to the degree to which the individual interacts with a broad spectrum of contacts, including decision-makers.
- **Responsibility for work outcome.** This relates to accuracy and extent to which the individual is held accountable for his or her work and decisions.

Experience credit may be given for research, teaching, or industrial hygiene program administration if done at a professional level.

Broad-Scope Industrial Hygiene

A candidate must also be practicing “broad-scope” industrial hygiene. Two dimensions are evaluated in judging the scope of experience:

- **Work function.** This includes the continuum of the process of industrial hygiene practice, which encompasses anticipation, recognition, evaluation, control, and management of occupational health hazards. Although no proportion of time devoted to each of these aspects is prescribed, broad-scope practice must exhibit experience in the entire process.
- **Stressor category.** This includes four generic categories of occupational health stressors: chemical, physical, biological, and ergonomic. Experience is expected in at least **two** of these four stressors.

Professional level experience that does not meet the broad scope criteria will be considered narrow-scope experience. A maximum of one year of narrow-scope experience may be credited toward eligibility.

Experience Equivalency

A **maximum** of one year of **experience equivalency** may be credited for certain industrial hygiene degrees from institutions acceptable to the Board.

- For bachelor’s level industrial hygiene degrees, six months’ experience credit will be awarded only when the program is accredited by the Accreditation Board for Engineering & Technology (ABET).
- For master’s level industrial hygiene degrees, one year of experience credit will be awarded only when the program is accredited by ABET.
- One year may be granted for an acceptable doctoral degree, provided that the degree is in industrial hygiene and that all academic requirements have been completed and the degree has been conferred.

Ineligible Experience

“Technician” or “pre-professional” experience does not count toward eligibility.

Research or teaching done as a student does not earn experience credit. However, paid internships (not receiving university credit) where the student is performing professional level activities may be used for experience credit.

An applicant who is otherwise qualified, but whose industrial hygiene career has been interrupted for one year or less – whether to pursue graduate studies in a cognate science, or for a medical reason, unemployment, or the like – may be considered to be “in practice” for purpose of determining examination eligibility. Time spent out of practice will not receive experience credit toward any future examination.

Master’s and Doctoral Students

After receipt of an acceptable bachelor’s degree, a master’s student in an industrial hygiene program accredited by the Accreditation Board for Engineering & Technology (ABET) or an industrial hygiene doctoral student may be considered to be in “industrial hygiene practice” for the purpose of determining his or her eligibility for examination. Only the *completed* degree will be credited toward experience equivalency.

REFERENCES

The applicant must provide a *minimum* of two professional references.

- **Supervisor.** A reference from an applicant’s current supervisor is required to document current industrial hygiene practice. There must be a reference from the applicant’s immediate supervisor(s) covering the entire time period for which the applicant requests experience credit. When an applicant is (or was) a principal in a business, the Board will accept references from major clients.
- **Certified Industrial Hygienist.** There must also be a reference from a CIH who is familiar with the applicant’s industrial hygiene work and can describe, from firsthand experience, the nature of the applicant’s industrial hygiene responsibilities. The CIH reference may also be a supervisory reference.

Alternatives to CIH

- In the event that no CIH is available who is familiar with the applicant’s industrial hygiene work, the applicant may substitute a reference from an individual certified at the professional level by an organization whose industrial/occupational hygiene certification scheme has been recognized by the International Occupational Hygiene Association (IOHA).
- Another alternative to a CIH reference is for the applicant to provide three written work samples demonstrating a range of industrial hygiene activities. Work samples may include reports; internal memos dealing with industrial hygiene activities; written programs/procedures; or other correspondence that helps to establish the content and professional level of the work. The samples must span the time period being claimed as professional level experience and be identifiable as the applicant’s own work. Work samples will *not* be returned unless specifically requested in advance.

Submitting the References

- Each reference must be provided on the Board’s Professional Reference Questionnaire (PRQ) form, have an original signature, and be prepared only by the person giving the reference.
- It is *unacceptable* for the applicant to complete the form and then have it signed by his or her reference.
- Each PRQ must be mailed, faxed, or emailed directly to ABIH by the person giving the reference.

Unqualified References

References will not be accepted from:

- An applicant's spouse or other relative
- A person whom the applicant supervises
- A member of the Board

In addition, references are not accepted if written by the applicant.

A Professional Reference Questionnaire that does not comply with the requirements of this section will not be accepted by ABIH. Each Professional Reference Questionnaire shall remain confidential between the author and ABIH.

TEST ACCOMMODATIONS

In accordance with the Americans with Disabilities Act (ADA), as amended, and other applicable laws, ABIH does not discriminate against individuals with disabilities in providing access to its examination program.

If an applicant has a documented disability and requires test accommodations, he or she must submit a Test Accommodation Request Form, which can be found on the ABIH website at <http://www.abih.org/become-certified/test-accommodations>. The request form and supporting documentation must accompany the application form and be received by the application deadline (February 1/August 1).

REAPPLICANTS

The application deadlines of February 1 or August 1 apply to all materials and fees that must be submitted by reapplicants.

Less Than Two Years

A reapplicant whose original approval or re-approval was less than two years ago and who wishes to be examined for the first time or to be re-examined must:

- Submit a Reapplication Request
- Pay the \$75 reapplication fee

More Than Two Years

A reapplicant whose original approval or re-approval was more than two years ago and who wishes to be examined for the first time or be re-examined must:

- Submit a Reapplication Form
- Obtain a Professional Reference Questionnaire from a current supervisor (see the References section above)
- Meet all current application requirements, including current practice
- Pay the \$75 reapplication fee

If the file of a reapplicant who was **previously approved** has been destroyed because of record retention requirements, the reapplicant must:

- Submit a Reapplication Form
- Obtain a Professional Reference Questionnaire from a current supervisor (see the References section above)
- Meet all current application requirements, including current practice
- Pay the \$150 application fee

If the file of an applicant *previously not approved* has been destroyed, all the requirements for new applicants, including the \$150 application fee, must be met.

APPLICATION and REAPPLICATION DEADLINES

All documentation required for the review and approval of an application or reapplication must be postmarked, faxed, or emailed by February 1 when applying for the Spring examination and by August 1 for the Fall examination.

Examinations are held each year at Prometric testing centers during two testing window periods.

- Examinees approved for the Spring examination can make an appointment with Prometric for either April or May.
- Fall examinees can schedule for either October or November.

The examination can be taken only once during a particular test window period.

FEES

Each applicant must submit an application or reapplication fee as well as an examination fee for each examination taken. These fees are nonrefundable, with exceptions noted below.

Application fee: \$150

Reapplication fee: \$75

An applicant or reapplicant declared ineligible for examination may resubmit or modify his or her application on the basis of new or supplemental information within two years of the filing date of the initial application without paying an additional reapplication fee.

Examination Fee \$350

If a candidate cancels his or her examination with the testing center at least 48 hours in advance of the scheduled exam, the fee will be carried over to the next exam window. If the cancelation is made less than 48 hours in advance, the fee is forfeited.

EXAMINATION INFORMATION

GENERAL

The examination is designed to test an individual's knowledge across the broad general practice of industrial hygiene. The candidate should expect questions in all rubrics (subject areas).

The exam contains 180 multiple choice questions that are selected to match the job analysis. The questions are not grouped by subject area in the examinations. The job analysis and rubric definitions currently in use by the Board can be found on pages 15 to 22 of this handbook.

The examination is conducted in two sections. Examinees may go back and review questions at any time during a section. The test will be 2.5 hours for the first section, an optional thirty minute break, and then 2.5 hours for the second section. There is a short tutorial prior to the examination and a short survey following the exam. You can submit comments about the content of specific exam questions during the exam by following the instructions on the exam. Comments will be reviewed however, for exam security reasons, ABIH will not be able to discuss the comments with the examinee who submitted them.

If an examinee chooses to take the thirty minute break, he or she has a maximum of 30 minutes. In other words, the second section of the exam will begin after 30 minutes regardless of when the examinee returns from break.

Also see the section Scoring of Examinations, below.

EXAMINATION PROCEDURES

Scheduling Your Appointment

Your examination fee must be paid before you will be able to schedule an examination. You will not appear in Prometric's computer file of approved examinees until your examination fee has been paid.

To ensure that you obtain the location and date you prefer, you should call Prometric immediately or go online to schedule an appointment. You must schedule your exam at least 9 calendar days prior to the end of the testing window to be able to sit for the exam.

You will need to provide the following information when scheduling your appointment:

- Your name
- Your identification number (listed in the Authorization to Test letter)
- A daytime telephone number
- The name of the examination sponsor (ABIH)
- The examination you are taking (CIH)

Scheduling Online

We recommend that you schedule your appointment online, since it is a faster and more efficient process. Go to www.prometric.com/abih. You must have an email address to schedule online.

If you schedule online, you will receive email confirmation of your appointment.

Scheduling by Phone

If you are scheduling by phone in North America, call Prometric's Customer Service Contact Center (CSCC) at (800) 800-1123. Operators are available from 8 a.m. to 8 p.m. (Eastern Time) Monday through Friday. Please note that you will not receive written notification concerning your appointment if you schedule via telephone.

If you are an international examinee, please check the Prometric website for the country specific [telephone numbers](#):

Confirmation Number

When you schedule your appointment either by telephone or online, you will receive a confirmation number. Make sure you keep a record of your confirmation number and appointment information. You will need your confirmation number if you want to confirm, reschedule, or cancel your appointment.

Test Site Location

You may take your examination at Prometric Testing Centers (PTC) in the United States, Canada, Puerto Rico, Guam, U.S. Samoa, the Virgin Islands, and internationally.

Determine the best PTC location for taking your examination by selecting Locate a Test Center on Prometric's website, www.prometric.com/abih.

- When scheduling your appointment, you should confirm the address of your test center and obtain directions.
- You may obtain directions to the PTC at Prometric's website or by calling Prometric's Customer Service Contact Center.

Examination Window

The candidate must test during the window for which he or she is approved.

- The Spring testing window opens on April 1 and closes on May 31.
- The Fall testing window opens October 1 and closes November 30.

Confirming Your Appointment

It is your responsibility to verify that you have been scheduled for the date, time, and place you have requested.

You may confirm your appointment in two ways.

- Call (800) 800-1123 or the applicable [international number](#) and select the option for confirming your appointment.
- Confirm your appointment online at www.prometric.com/abih.

You can confirm your appointment online even if you scheduled your appointment via telephone.

Examination Day

What to Bring

Plan to arrive at the test center at least 30 minutes prior to your scheduled exam time. Be sure to bring these three items:

- Your Authorization to Test (ATT) letter from the Board.
- Your current, valid, government-issued photo identification document with a signature (e.g., driver's license or passport). Security measures, including the capture of a digital fingerprint and information from your identification (including an image of your photo), will be implemented.
- An approved calculator from the list below.

If you do not provide the required identification or fully participate in the identity validation process during check-in and breaks, you will not be permitted to test, and you will forfeit the testing fees.

Approved Calculators for the Exam

Examinees may bring one or two **nonprogrammable** calculators selected from the approved list below. Any calculator within the series listed in the information provided to candidates is acceptable. Not all models within a series are listed because of the variety and the model changes that take place. For example, the listing of a Texas Instruments TI-30 as “approved” means that such models as the TI-30X, TI-30Xa, TI-30XII, TI-30XII S are all acceptable. The Prometric instructions to their staff indicate this, so the person checking you in at the Prometric test center will be aware that these are acceptable calculators.

Approved Calculator List

Casio – Models FX-115, FX-250, FX-260, FX-300, FX-350 and FX-991.

Hewlett-Packard – Models hp-9S, hp-10S, hp-30S, and hp-300S. **Note: hp-9G is not acceptable.**

Texas Instruments – Models TI-30, TI-34, TI-35, and TI-36.

What Not to Bring

The test center will provide materials for working out calculations. In addition, the ABIH Equation Sheets and plates from the *ACGIH Ventilation Manual* will be available on the computer on which you are taking your exam. (Click on the Reference button.)

The examinee may bring no other items into the examination room. These banned items include but are not limited to:

- cellphones
- pagers
- watches
- books and manuals
- notes or reference materials
- PDAs or other electronic devices
- food and drinks

Canceling, Rescheduling, and Missed Exams

If you need to cancel, delay, or change your examination location, you must do so at least 48 hours in advance of your scheduled exam. You may cancel or reschedule by calling (800) 800-1123 or the applicable [international number](#). You will need to provide your confirmation number.

If you miss your examination appointment, you will not be rescheduled and you will forfeit the testing fees.

If you are late for your examination appointment, you may not be admitted. Late admission is at the discretion of the Prometric testing center.

If you decide to delay your examination to a future examination window, please consult your Authorization to Test letter for reapplication details.

Problems with Prometric Scheduling and Testing

You should call ABIH at (517) 853-5763 if you encounter either of the following problems:

- You cannot schedule an exam because the Prometric operator does not have a file with your name and identification number.
- You arrive at your scheduled examination appointment but are unable to test due to Prometric technical or personnel difficulties.

SCORING OF EXAMINATIONS

The passing score is a total number of questions answered correctly. It will be to the candidate's advantage to attempt to answer all questions.

- All questions have the same point value.
- There is no penalty for incorrect answers (such as “number correct minus a percentage of the number of incorrect answers”).
- A “passing” score is **not** required in each of the individual rubrics.

A criterion-referenced passing score has been established by a panel of Certified Industrial Hygienists, using appropriate standard-setting procedures under the guidance of CASTLE Worldwide, Inc. The passing score for each subsequent administration of the certification examination is based on a statistical equating process, which adjusts for fluctuations in difficulty levels across different versions of the examination. Equating is performed to help ensure that candidates are evaluated according to the same competency standard from year to year.

An examinee may request a review of their exam score by filling out the Review of the Exam Score Form (located on the ABIH website in the [Document Library](#)) which will be forwarded to our testing vendor who will conduct a score verification. The examinee should consider that given the quality control procedures that are in place, it is highly unlikely that the score will change.

NOTIFICATION

Each examinee is informed of his or her pass/fail status immediately after completing the examination.

These are preliminary results, pending verification by the examination consultants and ABIH. Examinees will receive their official results in writing approximately four weeks after taking the examination.

An examinee who fails an examination will be informed of his or her overall score.

All examinees receive a performance report indicating scores in the individual rubrics.

As noted in the ABIH Privacy Policy, examination reports, scores, and failures are not released outside of ABIH without authorization from the examinee. The names of those who pass the examination will be listed on the ABIH website and entered in the web Rosters.

EXAMINATION PREPARATION

The ABIH Board encourages each candidate to consider his or her knowledge and experience in the light of the examination rubrics, and to assess his or her recognized strengths and weaknesses.

Self-study, specific training, and group discussions are recognized methods of improving perceived weaknesses. However, please note that the Board does not endorse or support training courses, study guides, or other activities that are intended or purported to be preparation for its examinations.

In order to familiarize candidates with the nature and form of questions that may be found in the examination, this Candidate Handbook includes a selection of sample questions below.

SAMPLE QUESTIONS

The following are provided as examples of the nature and type of questions which may be found in the Board's examinations. Their subject matter and level of difficulty do not necessarily reflect that which will be found in the examinations.

1. A mixture contains:

50 mL benzene (m.w.=78) v.p.= 75 mm, Hg; sp. gr.= 0.879.
25 mL carbon tetrachloride (m.w. = 154), v.p. = 91 mm, Hg; sp. gr. = 1.595
25 mL trichloroethylene (m.w. = 131.5), v.p. = 58 mm, Hg;
sp. gr. = 1.455.

Assuming Raoult's Law is obeyed, what will be the concentration of benzene in air at 760 mm Hg saturated with vapor of the above mixture?

1. 3.5%
 2. 4.5%
 3. 5.1%
 4. 9.9%
2. Which one of the following health effects may be manifested by chronic overexposure to benzene?
1. Abdominal colic
 2. Bladder tumors
 3. Cholinesterase depression
 4. Leukemogenic cancer
3. What is the ACGIH Threshold Limit Value for fluoride primarily intended to guard against?
1. delayed lung edema
 2. mottling of tooth enamel
 3. respiratory tract irritation
 4. tubular kidney injury
4. Under usual operating conditions, what is the static pressure at the discharge side of a fan with 10' length of discharge duct?
1. equal to the velocity pressure
 2. less than the atmospheric pressure
 3. equal to the total pressure
 4. greater than the atmospheric pressure
5. 1,000 cfm is to be drawn into a round, freely suspended duct of 6" diameter. What is the expected centerline velocity at 4" outside the duct opening?
1. 286 fpm
 2. 534 fpm
 3. 765 fpm
 4. 915 fpm

6. Two separate noise sources of 98 dBA and 96 dBA respectively are installed and operated together. What is the combined noise level?
1. 99 dBA
 2. 100 dBA
 3. 101 dBA
 4. 194 dBA
7. A maintenance worker must enter an empty reactor vessel for cleaning, inspection and lining repair. In the absence of continuous ventilation and testing of the air in the vessel, what should an industrial hygienist recommend?
1. an organic vapor respirator for the worker and a helper with a life line within earshot
 2. performance of the work at night with prior notice to the city's Emergency Response Unit
 3. flushing the tank with a suitable organic solvent before the worker enters
 4. a SCBA and fixed life line for the worker and a helper directly outside the tank
8. Workers in a brass foundry complain of a fever and general malaise on Mondays following a weekend respite from work. What should an industrial hygienist be equipped to obtain, upon arriving at the foundry?
1. blood samples to detect carbon monoxide exposures
 2. air samples to measure exposures to zinc fume
 3. potable water samples to detect PCB concentration
 4. urine samples to measure exposures to lead
9. What do the radioisotopes ^{238}U , ^{40}K , ^{226}Ra , and ^{235}U have in common?
1. Each is an alpha emitter.
 2. Each is a neutron emitter.
 3. Each occurs in nature.
 - Each has an analogue normally found in the human body.
10. Why is stack sampling for particulate aerosols done in an isokinetic manner?
1. to avoid size discrimination of collected particles
 2. to minimize particle deposition in the sampling tube
 3. to collect the respirable size particles only
 4. to collect samples suitable for direct analysis
11. Theoretically, what is the minimum number of sound pressure level measurements needed to determine the sound power output from a non-directional noise source in a free field?
1. one
 2. two
 3. four
 4. eight
12. What are too many levels of management, chronic and recurring internal problems, and numerous meetings attended by many people typically symptoms of?
1. poor communications
 2. lack of management training
 3. poor employee morale
 4. a flawed organizational structure

REFERENCES

ABIH examination questions are taken from a variety of sources in the literature. The intention is to reflect the underlying purposes and principles of industrial hygiene as well as the current knowledge that is expected of the industrial hygienist.

The Board suggests that candidates refer to the publications areas of the websites of ACGIH (<http://www.acgih.org>), AIHA (<https://www.aiha.org>), and NIOSH (<http://cdc.gov/niosh/pubs.html>). Candidates also may consult relevant books by such publishers as CRC Press, Lewis Publishers, McGraw Hill, and John Wiley & Sons for lists of available resources.

CIH® EXAM BLUEPRINT
Based on the 2014 Job Analysis
(Effective April 1, 2015)

The test specifications below identify three domains of performance and nine tasks. A domain is a major area of responsibility that defines the role of a Certified Industrial Hygienist® (CIH®) practitioner. A task is an activity performed within a performance domain. Knowledge and skills candidates should possess in order to perform the tasks are also included.

Domain I: Exposure Assessment Principles and Practice
50%

Task 1. Anticipate and recognize potential health hazards by studying environments, tasks, and people to identify risks associated with stressors, products, and processes.

Knowledge of:

1. Basic math and sciences
2. Biological/chemical/physical/ergonomic hazards
3. Industry, including raw materials, intermediates, final products, and waste streams
4. Process (unit operations) knowledge
5. Toxicology
6. Standards and guidelines
7. Epidemiology
8. Environmental sciences
9. Public health (community health)
10. New process/chemical evaluation (pre OEL)

Skill in:

1. Extracting critical information from literature, standards, guidelines and other resources
2. Prioritizing hazards for evaluation
3. Anticipating exposure scenarios
4. Recognizing known potential hazards
5. Inventorying hazards
6. Surveying tasks, operations, and sites
7. Communicating with affected parties
8. Exposure reconstruction & forensic investigation

Task 2. Assess the relationship between exposure and the potential adverse health effects to determine if further action is warranted using recognized scientific principles, literature, and standards.

Knowledge of:

1. Basic math and sciences
2. Statistics
2. Biological/chemical/physical/ergonomic hazards
3. Industry/work environments
4. Process (unit operations) knowledge
5. Toxicology
6. Epidemiology

7. Environmental sciences
8. Public health (community health)
9. Risk assessment
10. New process/chemical evaluation (pre-OEL)

Skill in:

1. Applying principles and concepts of toxicology (dose response, acute/chronic, latency, routes of entry)
2. Applying principles and concepts of epidemiology (study design, measures of disease, and statistics)
3. Assessing information source credibility
4. Communicating with affected parties

Task 3. Design and implement an exposure assessment strategy (qualitative and/or quantitative) to determine the extent and magnitude of exposure using relevant principles to ensure scientific validity.

Knowledge of:

1. Basic math and sciences
2. Statistics
3. Biological/chemical/physical/ergonomic hazards
4. Industrial knowledge/work environments
5. Process (unit operations)
6. Sampling methods and instrumentation
7. Analytical chemistry
8. Study design
9. Standards/guidelines
10. Medical surveillance/monitoring technologies

Skill in:

1. Designing exposure assessment strategies
2. Applying statistical principles to study design
3. Identifying appropriate exposed population(s)
4. Selection and use of appropriate sampling methods (instrumentation, analysis, strengths and limitations)
5. Reviewing pertinent information (historical sampling data, existing controls, materials inventory, process review, work practices)
6. Identifying routes of exposure
7. Implementing qualitative & quantitative exposure assessment strategies
8. Developing and managing projects
9. Conducting basic research
10. Operating instruments, including calibration
11. Keeping field records
12. Communicating with affected parties
13. Identifying appropriate analytical methods

Task 4. Formulate conclusions, prioritize risks, and communicate findings and recommendations based on analysis and evaluation of data using standards, guidelines and ethical professional judgment.

Knowledge of:

1. Basic math and sciences
2. Biological/chemical/physical/ergonomic hazards

3. Industry/work environments
4. Process (unit operations)
5. Toxicology
6. Analytical chemistry
7. Standards and guidelines
8. Epidemiology
9. Risk communication
10. Statistics
11. Hierarchy of controls
12. Environmental sciences
13. Public health (community health)

Skill in:

1. Analyzing sample data
2. Comparing sampling results to known standards/guidelines
3. Evaluating the quality of data (both new and old)
4. Evaluating potential risks of previously unrecognized hazards
5. Identifying potential risks of complex/complicated exposure scenarios
6. Developing & managing projects including risk management, evaluation of business impacts, sustainability and product stewardship
7. Characterizing risk (affected parties)
8. Communicating risk (oral, written)

Domain II: Control Selection, Implementation, and Validation
35%

Task 1. Assess and select options to eliminate or mitigate exposure using the hierarchy of controls and recognized scientific principles, literature, standards, and design and performance criteria.

Knowledge of:

1. Hierarchy of controls
2. Ventilation design (local exhaust, dilution and HVAC)
3. Basic math and sciences
4. Aerosol science
5. Industrial processes and unit operations
6. Controls of biological, chemical, physical and ergonomic hazards
7. Hazardous material and remediation response
8. Principles of radiation and other physical energy protection (time, distance, shielding)
9. Principles of noise and noise abatement
10. Principles of thermal stressor control
11. PPE (protection factors, protective clothing, permeability/degradation, NRR)
12. Toxicology and routes of entry
13. Physiology and anatomy
14. Physical properties and chemical incompatibility
15. Work routines/work environments
16. Education and training
17. Work practices
18. Community exposure
19. Business impacts, sustainability and product stewardship
20. Exposure guidelines
21. Impact of the environment and people on the controls selected

Skill in:

1. Designing hazard controls (ventilation, noise abatement, radiation/physical energy, systems, PPE)
2. Measuring air flow parameters
3. Applying hierarchy of controls
4. Defining the relevant physical properties of chemical and biological materials
5. Selecting proper PPE based on strengths and limitations
6. Evaluating the environment in which the control is to be used
7. Developing and managing projects including risk management, evaluation of business impacts, sustainability and product stewardship
8. Determining frequency, probability and severity of exposure
9. Considering individual differences in workers
10. Interpreting building specifications

Task 2. Develop and implement appropriate control programs and techniques designed to eliminate or mitigate exposure, using standards, guidelines, literature and ethical professional practice.

Knowledge of:

1. Design of hazard controls (ventilation, noise abatement, radiation/physical energy, systems, PPE)
2. Requirements for writing performance specifications
3. Coordinating financial and staff resources
4. Procedures for training personnel in the use and application of control method
5. Industrial processes and unit operations (routine and emergency)
6. Hierarchy of controls
7. Communication strategies and tools
8. PPE selection and limitations
9. Reporting structures, roles and responsibilities
10. Emergency response programs and principles

Skill in:

1. Designing control systems
2. Project management
3. Training strategies and tools
4. Applying exposure abatement technologies
5. Remediating biological, chemical, physical and ergonomic hazards
6. Responding to chemical hazard emergencies
7. Applying ergonomic interventions
8. Interpreting engineering instructions and specifications
9. Policy development

Task 3. Validate the effectiveness of controls to eliminate or mitigate exposure using recognized scientific principles, literature, standards, and design and performance criteria.

Knowledge of:

1. Basic math and sciences
2. Aerosol science
3. Statistics
4. Principles of radiation and other physical energy protection (time, distance, shielding)
5. Principles of noise and noise abatement
6. Principles of thermal stressor control
7. Air sampling (chemical and biological agents)

8. Measurement techniques (ventilation, radiation, noise, thermal stress, vibration)
9. Microbiology
10. Ergonomic risk factors
11. Industrial process and unit operations (routine and emergency)
12. Application of exposure guidelines
13. Application of acceptable ventilation criteria
14. Hierarchy of controls
15. Control specifications
16. Equipment/technology used to validate control effectiveness
17. Auditing and quality assurance procedures
18. Basic research techniques

Skill in:

1. Selection and use of appropriate sampling methods (instrumentation, analysis, strengths and limitations)
2. Ventilation measurements
3. Noise and vibration measurements
4. Radiation measurements
5. Thermal stress measurements
6. Comparing air sampling and measurement data to recognized criteria
7. Troubleshooting control technology
8. Reading and interpreting design drawings and specifications
9. Developing & managing projects including risk management, evaluation of business impacts, sustainability and product stewardship
10. Program auditing

Domain III: Risk Management **15%**

Task 1. Develop and implement programs/systems that address health risks using recognized risk-based methods and scientific principles, literature, standards and effective communication strategies.

Knowledge of:

1. Industrial hygiene program management principles and best practices
2. Risk assessment principles
3. Standards and guidelines
4. Audit and quality assurance procedures
5. Communication strategies and tools
6. Emergency response programs and principles
7. Procedures for training personnel

Skill in:

1. Communicating and interpreting regulatory requirements and communicating with regulatory agencies
2. Communicating industrial hygiene program components, including report writing and presentation
3. Managing program resources
4. Integrating industrial hygiene program needs into business plans
5. Prioritizing program needs
6. Identifying appropriate target audiences
7. Identifying appropriate program performance measurements
8. Communicating risk to affected parties
9. Program auditing

10. Understanding rationale for and application of occupational and environmental exposure limits (BEIs, TLVs)
11. Training strategies and tools

Task 2. Evaluate and maintain the effectiveness of programs/systems designed to eliminate or mitigate exposure using regulations, standards, guidelines, and ethical professional practice.

Knowledge of:

1. Industrial hygiene program management principles and best practices
2. Risk assessment principles
3. Standards and guidelines
4. Communication strategies and tools
5. Procedures for training personnel
6. Audit techniques and quality assurance procedures
7. Data management systems and record keeping requirements
8. Program performance measurements and metrics

Skill in:

1. Communicating industrial hygiene program components, including report writing and giving presentations
2. Communicating standards and guidelines
3. Managing program resources
4. Prioritizing program needs
5. Training strategies and tools
6. Program auditing
7. Collecting and analyzing performance data
8. Performing program management analysis

RUBRICS DEFINITIONS

Examination questions are categorized in the following rubrics (subject areas):

Air Sampling and Instrumentation

Selection, use and limitations of field air-sampling instruments, full-shift and grab samples, including direct-reading instruments. Also included are the set-up, calibration and use (including quality assurance practices) of air-sampling apparatus and direct-reading instruments, sampling strategy considerations and calculations related to sampling and calibration. Measurement of exposures to noise, ionizing radiation, nonionizing radiation, and thermal stressors are included in the rubrics dealing with those specific subject areas.

Analytical Chemistry

Laboratory analytical procedures for work place environmental samples and related calculations. Included are gas chromatography, infrared, visible and ultraviolet spectrophotometry, high performance liquid chromatography, mass spectroscopy, atomic absorption spectrophotometry, wet chemical methods, and microscopy and laboratory quality assurance and chain of custody.

Basic Science

General scientific concepts, chemistry, biochemistry, biology, anatomy and physiology, general physics and mathematics. Properties of flammable, combustible and reactive materials (compatibility) are included as are calculations such as those relative to gas laws, airborne concentrations, and unit-of-measure conversions and conditions of non-standard pressure.

Biohazards

Principles of sanitation, personal hygiene, the recognition, evaluation and control of biological agents or materials having the capacity to produce deleterious effects upon other biological organisms, particularly humans (virus, bacteria, fungi, molds, allergens, toxins, recombinant products, bloodborne pathogens, etc.) and infectious diseases that appear in workplaces including industry, agriculture, homes, offices and health care facilities.

Biostatistics & Epidemiology

Principles of epidemiology, techniques used to study the distribution of occupationally induced diseases and physiological conditions in workplaces and factors that influence their frequency. It includes concepts of prospective and retrospective studies, morbidity and mortality and animal experimental studies, data and distribution of data as well as basic biostatistics and statistical and non-statistical interpretation of data in the evaluation of hazards.

Community Exposure

Air pollution, air cleaning technology, ambient air quality considerations, emission source sampling, atmospheric dispersion of pollutants, ambient air monitoring, health and environmental effects of air pollutants and related calculations. Also included are other IH related environmental subjects such as emergency planning and response, water pollution, hazardous waste, and environmental fate and transport.

Engineering Controls/Ventilation

Control of chemical and physical exposures through engineering measures such as local exhaust ventilation, dilution ventilation, isolation, containment and process change. Also included are mechanics of airflow, ventilation measurements, design principles and related calculations as well as in-plant recirculation air-cleaning technology.

Engineering control of ionizing and nonionizing radiation, thermal stressors, and noise and vibration sources including principles of isolation, enclosure, absorption and damping are included in the rubrics dealing with those specific subject areas.

Ergonomics

Application of principles from anthropometry, human factors engineering, biomechanics, work physiology, human anatomy, occupational medicine and facilities engineering to the design and organization of the workplace for the purpose of preventing injuries and illnesses.

Health Risk Analysis and Hazard Communication

Understanding of principles and requirements for the interpretation and use of guidelines for the assessment of health hazards, including American Conference of Governmental Industrial Hygienists (ACGIH) Threshold Limit Values (TLVs), Biological Exposure Indices (BEIs) and industrial ventilation guidelines, American National Standards Institute (ANSI) standards, American Society for Heating, Refrigeration, and Air Conditioning Engineers (ASHRAE) guidelines, American Society for Testing and Materials (ASTM) standards, and National Institute for Occupational Safety and Health (NIOSH) Criteria Documents and recommendations. Understanding of the risk reduction process including the hierarchy of controls, control banding and hazard communication and training of employees are included. Communication of recommendations by appropriate techniques to implement control actions is also included.

IH Program Management

Acquisition, allocation and control of resources to accomplish industrial hygiene anticipation, recognition, evaluation and control objectives in an effective and timely manner. Included are such topics as auditing, investigation methods, data management and integration, establishment of policy, planning, delegation of authority, accountability, risk communication, organizational structure, decision making and the ABIH Code of Ethics.

Noise

Health effects resulting from exposure to noise and vibration. Computations related to combining noise sources and octave band measurements are included as are audiometric testing programs. Includes exposure measurement, evaluation, and control.

Non-Engineering Controls

Personal protective equipment, including the principles governing selection, use and limitations of respirators and protective clothing. Included are respirator fit testing, breathing air specifications, glove permeability, eye protection and the use of administrative controls.

Radiation/Ionizing

Physical characteristics and health and biological effects associated with alpha, beta, gamma, neutron and x-radiation, including source characteristics. Includes exposure measurement, evaluation, and control.

Radiation/Nonionizing

Physical characteristics and health effects associated with electromagnetic fields, static electric and magnetic fields, lasers, radio frequency, microwaves, ultraviolet, visible, infrared radiation and illumination. Includes exposure measurement, evaluation, and control.

Thermal Stressors

Adverse health effects associated with heat and cold, symptoms of temperature-related health effects, exposure control techniques, and first-aid/medical response.

Toxicology

Health effects resulting from exposure to chemical substances including single agents and mixtures, and natural and synthetic agents. Included are symptomatology, pharmacokinetics, mode of action, additive, synergistic and antagonistic effects, routes of entry, absorption, metabolism, excretion, target organs, toxicity testing protocols and aerosol deposition and clearance in the respiratory tract. Also included are carcinogenic, mutagenic, teratogenic and reproductive hazards.

Work Environments and Industrial Processes

Included are the hazards associated with specific industrial or manufacturing processes. Topics include, but are not limited to confined space entry, spray-painting, welding, abrasive-blasting, vapor-degreasing, foundry operations, and hazardous waste site remediation, as well as general indoor environmental issues.

EQUATION SHEET

The following pages of equations and conversions will be available on the computer on which the exams are given for use during the examinations. The following plates from the 24th Edition of the ACGIH “Ventilation Manual” will also be available on the computer for use during the examinations: 3-11, 3-16, 5-15, 5-16, 5-17 and 5-18.

USEFUL EQUATIONS FOR THE ABIH EXAMINATIONS

This list of equations is offered as assistance in taking the ABIH examinations. No assurance is given that this list is complete or that the use of this list will assure the successful completion of any examination. The variables used are the same as found in the reference source for the equation. No attempt has been made to standardize variables.

VENTILATION

$$Q = VA \quad V_1 A_1 = V_2 A_2 \quad TP = VP + SP \quad SP_1 + VP_1 = SP_2 + VP_2 + h_L \quad V = 4005\sqrt{VP} \quad |SP_h| = VP + h_e$$

$$h_e = \frac{1 - C_e^2}{C_e^2} VP \quad h_e = F_h x VP_d \quad C_e = \sqrt{\frac{VP}{|SP_h|}} \quad VP_{ave} = \left(\frac{\sqrt{VP_1} + \sqrt{VP_2} + \dots + \sqrt{VP_n}}{n} \right)^2 \quad VP_r = \left(\frac{Q_1}{Q_3} \right) VP_1 + \left(\frac{Q_2}{Q_3} \right) VP_2$$

$$V = 1096 \sqrt{\frac{VP}{\rho}} \quad Q = 4005 C_e A \sqrt{|SP_h|} \quad Q = 4005 A \sqrt{\frac{SP_h}{df(1 + F_h)}} \quad Q = 1096 A \sqrt{\frac{SP_h}{\rho(1 + F_h)}} \quad Q_{cor} = Q_{design} \sqrt{\frac{SP_{gov}}{SP_{duct}}}$$

$$Q' = \frac{Q}{K} \quad t_2 - t_1 = -\frac{V_r}{Q'} \ln \left(\frac{C_2}{C_1} \right) \quad \ln \left(\frac{G - Q' C_2}{G - Q' C_1} \right) = -\frac{Q'(t_2 - t_1)}{V_{room}} \quad C = \left(\frac{G}{Q'} x 10^6 \right) + C_{supply}$$

$$N_{changes} = \frac{60Q}{V_{room}} \quad C = \frac{G}{Q'} (1 - e^{-Nt/60}) x 10^6 \quad C = C_0 e^{-tN_{changes}} \quad Q = \frac{(403)(s.g.)(ER)(K)(10^6)}{(m.w.)(C)} \quad C = \frac{gx24.45x10^6}{MWxV}$$

$$Q_2 = Q_1 \left(\frac{Size_2}{Size_1} \right)^3 \left(\frac{RPM_2}{RPM_1} \right) \quad P_2 = P_1 \left(\frac{Size_2}{Size_1} \right)^2 \left(\frac{RPM_2}{RPM_1} \right)^2 \quad PWR_2 = PWR_1 \left(\frac{Size_2}{Size_1} \right)^5 \left(\frac{RPM_2}{RPM_1} \right)^3$$

$$FSP = SP_{out} - SP_{in} - VP_{in} \quad FTP = TP_{out} - TP_{in}$$

NOISE

$$SPL = 20 \left(\log \frac{P}{P_0} \right) \quad SPL = 10 \left(\log \frac{I}{I_0} \right) \quad SPL_2 = SPL_1 + 20 \log \left(\frac{d_1}{d_2} \right)$$

$$SPL_f = 10 \log \sum 10^{\frac{SPL}{10}} \quad SPL_f = SPL_I + 10 \log(n) \quad L_w = 10 \log \left(\frac{W}{W_0} \right) \quad W_0 = 10^{-12} \text{ watts}$$

$$L_{Total} = L_1 + 10 \log \left(10^{\frac{L_2 - L_1}{10}} + 1 \right) \quad L_{eq} = 10 \log \left(\frac{1}{T} \sum_{i=1}^N \left(10^{\frac{L_i}{10}} t_i \right) \right) \quad L_{PT} = 10 \log \left(\sum_{i=1}^N 10^{\frac{L_{Pi}}{10}} \right) \quad TL = 10 \log \left(\frac{E_i}{E_t} \right)$$

$$L_p = L_w - 20 \log_{10} r - 0.5 + DI + T \quad DI = 10 \log_{10} Q \quad \%D = 100 \left(\frac{C_1}{T_1} + \frac{C_2}{T_2} + \dots + \frac{C_i}{T_i} \right)$$

$$T = 8/2^{(level-85)/3} \quad TWA_{eq} = 10 \log \left(\frac{\%D}{100} \right) + 85dBA \quad TWA = 16.61 \log \left(\frac{\%D}{100} \right) + 90dBA \quad f = \frac{(N)(RPM)}{60}$$

$$f = \frac{c}{\lambda} \quad f_2 = 2f_1 \quad f_c = \sqrt{f_1 f_2} \quad f_2 = \sqrt{2} f_1 \quad f_2 = \sqrt[3]{2} f_1$$

USEFUL EQUATIONS FOR THE ABIH EXAMINATIONS

This list of equations is offered as assistance in taking the ABIH examinations. No assurance is given that this list is complete or that the use of this list will assure the successful completion of any examination. The variables used are the same as found in the reference source for the equation. No attempt has been made to standardize variables.

GENERAL SCIENCES, STATISTICS, STANDARDS

$$ppm = \frac{V_{contam}}{V_{air}} \times 10^6 \quad ppm = \frac{P_v}{P_{atm}} \times 10^6 \quad ppm = \frac{mg/m^3 \times 24.45}{m.w.} \quad \frac{P_1V_1}{nRT_1} = \frac{P_2V_2}{nRT_2} \quad V_{TS} = \frac{gd_p^2(\rho_p - \rho_a)}{18\eta}$$

$$R_e = \frac{\rho dv}{\eta} \quad \log \frac{I_o}{I} = abc \quad pH = -\log_{10}[H^+] \quad K_a = \frac{[H^+]x[A^-]}{[HA]} \quad K_b = \frac{[BH^+]x[OH^-]}{[B]}$$

$$P_{total} = X_1P_1 + X_2P_2 + \dots + X_iP_i \quad \text{vapor/hazard ratio} = \frac{\text{sat. concentration}}{\text{exposure guideline}} \quad TLV_{mix} = \frac{C_1}{TLV_1} + \frac{C_2}{TLV_2} + \dots + \frac{C_n}{TLV_n}$$

$$TLV_{mix} = \frac{1}{\frac{F_1}{TLV_1} + \frac{F_2}{TLV_2} + \dots + \frac{F_n}{TLV_n}} \quad RF = \frac{8}{h} \times \frac{24-h}{16} \quad RF = \frac{40}{h_w} \times \frac{168-h_w}{128} \quad C_{asb} = \frac{(C_s - C_b)A_c}{1000A_fV_s} \quad C_{asb} = \frac{EA_c}{1000V_s}$$

$$E_{fiber\ density} = \frac{\frac{f}{N_f} - \frac{B}{N_b}}{A_f} \quad d = \frac{0.61\lambda}{\eta \sin \alpha} \quad \bar{X} = \frac{X_1 + X_2 + \dots + X_n}{n} \quad SD = \sqrt{\frac{\sum (x - \bar{x})^2}{n-1}} \quad GM = \sqrt[n]{(x_1)(x_2)\dots(x_n)}$$

$$GM = 10^{\frac{\sum(\log x)}{n}} \quad GSD = \frac{84.13\% \text{ tile value}}{50\% \text{ tile value}} \quad GSD = \frac{50\% \text{ tile value}}{15.87\% \text{ tile value}} \quad SAE = 1.645CV_{total} \quad CV = \frac{SD}{\bar{X}}$$

$$E_c = \sqrt{E_1^2 + E_2^2 + \dots + E_n^2} \quad t = \frac{\bar{x}_1 - \bar{x}_2}{SD_{pooled} \sqrt{\frac{1}{n_1} + \frac{1}{n_2}}} \quad SD_{pooled} = \sqrt{\frac{(n_1-1)SD_1^2 + (n_2-1)SD_2^2}{n_1 + n_2 - 2}}$$

$$LCL = \frac{C_A}{PEL} - \frac{SAE \sqrt{T_1^2 C_1^2 + T_2^2 C_2^2 + \dots + T_n^2 C_n^2}}{PEL(T_1 + T_2 + \dots + T_n)} \quad 95\% \text{ Conf} = \bar{X} \pm 1.645 \frac{SD}{\sqrt{n}} \quad 95\% \text{ Conf} = \bar{X} \pm 1.96 \frac{SD}{\sqrt{n}}$$

HEAT STRESS

$$WBGT = 0.7t_{nwb} + 0.2t_g + 0.1t_{db} \quad WBGT = 0.7t_{nwb} + 0.3t_g \quad \Delta S = (M - W) \pm C \pm R - E \quad R = 15(t_w - 95)$$

$$C = 0.65v^{0.6}(t_a - 95) \quad E_{max} = 2.4v^{0.6}(42 - vp_w) \quad cfm = \frac{\text{Total Sensible Heat (BTU / hr)}}{1.08(\Delta T)} \quad HSI = \frac{E_{req}}{E_{max}} \times 100$$

USEFUL EQUATIONS FOR THE ABIH EXAMINATIONS

This list of equations is offered as assistance in taking the ABIH examinations. No assurance is given that this list is complete or that the use of this list will assure the successful completion of any examination. The variables used are the same as found in the reference source for the equation. No attempt has been made to standardize variables.

RADIATION

$$I_2 = I_1 \left(\frac{d_1}{d_2} \right)^2 \quad \text{Rem} = (\text{RAD})(QF) \quad D = \frac{\Gamma A}{d^2} \quad A = A_i (0.5)^{\frac{t}{T_{1/2}}} \quad A_i = \frac{0.693}{T_{1/2}} N_i \quad A = A_i e^{\frac{-0.693t}{T_{1/2}}}$$

$$I = (1/2)^A I_0 \quad I = (1/10)^B I_0 \quad I_2 = \frac{I_1}{\frac{X}{2^{HVL}}} \quad I_2 = \frac{I_1}{10^{\frac{TVL}{X}}} \quad X = 3.32 \log \left(\frac{I_1}{I_2} \right) (\text{HVL}) \quad I = I_0 B e^{-\mu x}$$

$$\frac{1}{T_{1/2\text{eff}}} = \frac{1}{T_{1/2\text{rad}}} + \frac{1}{T_{1/2\text{bio}}} \quad T_{1/2\text{eff}} = \frac{(T_{1/2\text{rad}})(T_{1/2\text{bio}})}{T_{1/2\text{rad}} + T_{1/2\text{bio}}} \quad PD = \frac{E^2}{3770} \quad PD = 37.7 H^2 \quad W = \frac{4P}{A} \quad r = \left(\frac{PG}{4\pi EL} \right)^{1/2}$$

$$B_r = \sqrt{B_x^2 + B_y^2 + B_z^2} \quad r_{\text{NHZ}} = \frac{1}{\phi} \left(\frac{4\Phi}{\pi EL} - a^2 \right)^{1/2} \quad r_{\text{NHZ}} = \frac{f_0}{b_0} \left(\frac{4\Phi}{\pi EL} \right)^{1/2} \quad r_{\text{NHZ}} = \left(\frac{\rho\Phi \cos \theta}{\pi EL} \right)^{1/2} \quad D_s = \frac{1}{\phi} \left(\frac{4\Phi}{\pi TL} - a^2 \right)^{1/2}$$

$$\text{spatial ave} = \left(\frac{\sum_{i=1}^N FS_i^2}{N} \right)^{1/2} \quad t = \frac{0.003 \text{ J/cm}^2}{E_{\text{eff}}} \quad t = \frac{EL}{ML} \times 0.1 \text{ h} \quad O.D. = \log \frac{I_0}{I} \quad D_L = \sqrt{a^2 + \phi^2 r^2}$$

$$I_2 = I_1 x (\text{magnification})^2 \quad G = 10^{g/10}$$

CONSTANTS AND CONVERSIONS

$$^{\circ}\text{F} = 9/5(^{\circ}\text{C}) + 32 \quad ^{\circ}\text{R} = ^{\circ}\text{F} + 460 \quad \text{K} = ^{\circ}\text{C} + 273.15 \quad \text{molar volume at } 25^{\circ}\text{C}, 1 \text{ atm} = 24.45 \text{ L} \quad 1 \text{ ft}^3 = 28.32 \text{ L}$$

$$1 \text{ ft}^3 = 7.481 \text{ U.S. gal} \quad 1 \text{ L} = 1.0566 \text{ qt} \quad 1 \text{ inch} = 2.54 \text{ cm} \quad 1 \text{ lb} = 453.6 \text{ gm} \quad 1 \text{ gram} = 15.43 \text{ grains}$$

$$1 \text{ atm} = 14.7 \text{ psi} = 760 \text{ mm Hg} = 29.92 \text{ in Hg} = 33.93 \text{ ft water} = 1013.25 \text{ mbar} = 101,325 \text{ pascals}$$

$$1 \text{ Currie} = 3.7 \times 10^{10} \text{ disint/sec (Becquerel)} = 2.2 \times 10^{12} \text{ dpm} \quad 1 \text{ Gray} = 100 \text{ Rad} \quad 1 \text{ Sievert} = 100 \text{ Rem}$$

$$1 \text{ Tesla} = 10,000 \text{ Gauss} \quad 1 \text{ BTU} = 1054.8 \text{ joules} = 0.293 \text{ watt hr} \quad 1 \text{ cal} = 4.184 \text{ joules}$$

$$\text{speed of sound in air at } 20^{\circ}\text{C} = 1130 \text{ ft/sec} \quad \text{speed of light} = 3 \times 10^8 \text{ m/sec}$$

$$\text{Planck's constant} = 6.626 \times 10^{-27} \text{ erg sec} \quad \text{Avogadro's number} = 6.024 \times 10^{23}$$

$$\text{gas constant, R} = 8.314 \text{ J/mole K} = 0.082 \text{ L atm/mole K}$$

$$g = 981 \text{ cm/sec}^2 = 32 \text{ ft/sec}^2 \quad A_c = 385 \text{ mm}^2 \text{ for } 25 \text{ mm filter} \quad \text{density of air} = 1.29 \text{ g/L at } 1 \text{ atm}, 0^{\circ}\text{C}$$

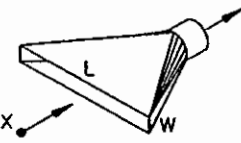
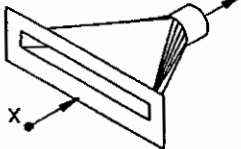
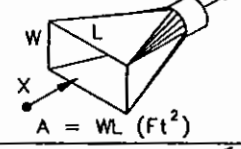
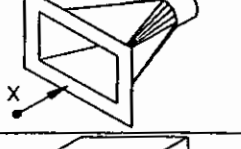
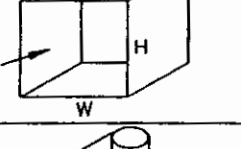
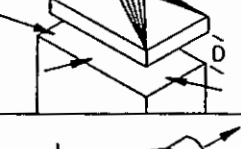
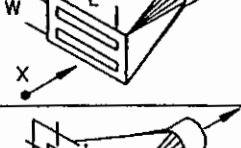
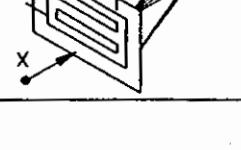
HOOD TYPE	DESCRIPTION	ASPECT RATIO, W/L	AIR FLOW
	SLOT	0.2 OR LESS	$Q = 3.7 LVX$
	FLANGED SLOT	0.2 OR LESS	$Q = 2.6 LVX$
	PLAIN OPENING	0.2 OR GREATER AND ROUND	$Q = V(10X^2 + A)$
	FLANGED OPENING	0.2 OR GREATER AND ROUND	$Q = 0.75V(10X^2 + A)$
	BOOTH	TO SUIT WORK	$Q = VA = VWH$
	CANOPY	TO SUIT WORK	$Q = 1.4 PVD$ SEE FIG. VS-99-03 P = PERIMETER D = HEIGHT ABOVE WORK
	PLAIN MULTIPLE SLOT OPENING 2 OR MORE SLOTS	0.2 OR GREATER	$Q = V(10X^2 + A)$
	FLANGED MULTIPLE SLOT OPENING 2 OR MORE SLOTS	0.2 OR GREATER	$Q = 0.75V(10X^2 + A)$

AMERICAN CONFERENCE
OF GOVERNMENTAL
INDUSTRIAL HYGIENISTS

HOOD TYPES

DATE 4-96

FIGURE 3-11

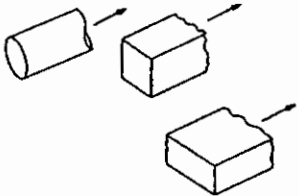
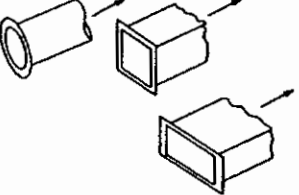
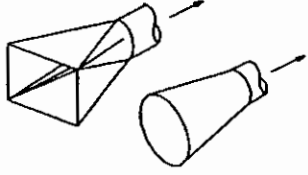
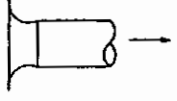
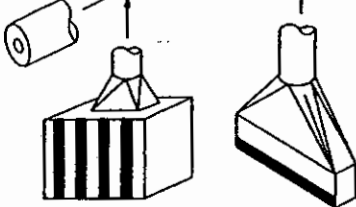
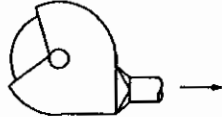
HOOD TYPE	DESCRIPTION	HOOD ENTRY LOSS (F _L) COEFFICIENT
	PLAIN OPENING	0.93
	FLANGED OPENING	0.49
	TAPER OR CONE HOOD	SEE CHAPTER 10
	BELL MOUTH INLET	0.04
	ORIFICE	SEE CHAPTER 10
	TYPICAL GRINDING HOOD	(STRAIGHT TAKEOFF) 0.65
		(TAPERED TAKEOFF) 0.40
AMERICAN CONFERENCE OF GOVERNMENTAL INDUSTRIAL HYGIENISTS		<p style="text-align: center;"><i>HOOD LOSS COEFFICIENTS</i></p> <p>DATE <i>4-96</i> FIGURE <i>3-16</i></p>

From American Conference of Governmental Industrial Hygienists: Industrial Ventilation: A Manual of Recommended Practice, 24th Edition; Copyright 2001, Cincinnati, Ohio. Reprinted with permission.



$h_e = 0.93 VP_d$
PLAIN DUCT END



$h_e = 0.49 VP_d$
FLANGED DUCT END

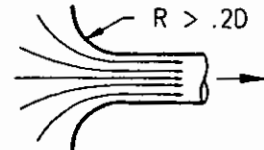

$h_e = 0.04 VP_d$
BELLMOUTH ENTRY

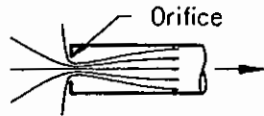

$h_e = 1.78 VP_{Orifice}$
SHARP-EDGED
ORIFICE

* $h_e = F_h VP_d$ See 3.5.1

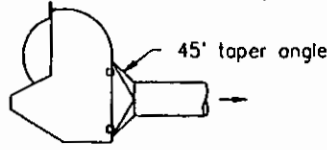

$h_e = 0.4 VP_d$ (topered take-off)
 $h_e = 0.65 VP_d$ (no toper)
STANDARD GRINDER HOOD

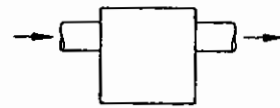

$h_e = 1.5 VP_d$
TRAP OR SETTLING CHAMBER

TAPERED HOODS

Flanged or unflanged; round, square or rectangular. θ is the major angle on rectangular hoods.

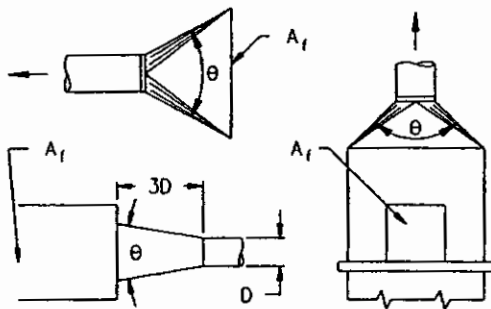

Face area (A_f) at least 2 times the duct area.

θ	ENTRY LOSS (h_e)	
	ROUND	RECTANGULAR
15°	0.15 VP	0.25 VP
30°	0.08 VP	0.16 VP
45°	0.06 VP	0.15 VP
60°	0.08 VP	0.17 VP
90°	0.15 VP	0.25 VP
120°	0.26 VP	0.35 VP
150°	0.40 VP	0.48 VP
180°	0.50 VP	0.50 VP

VP = Duct VP = VP_d
Note: 180° values represent round ducts butted into back of booth or hood without a rectangular to round transition.

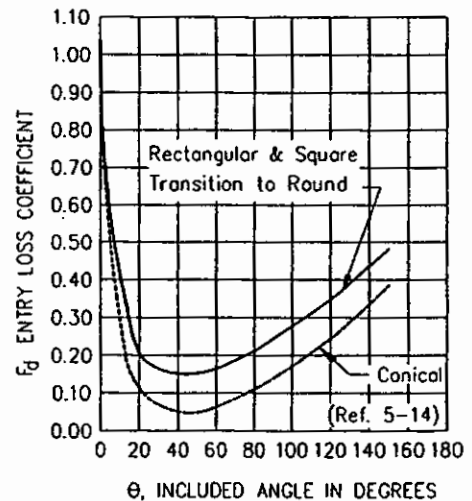

COMPOUND HOODS

A compound hood, such as the slot/plenum shown to the right, would have 2 losses, one through the slot and the other through the transition into the duct.

The slot entry loss coefficient, F_s , would have a value typically in the range of 1.00 to 1.78 (see Chapters 3 and 10).

The duct entry loss coefficient is given by the above data for tapered hoods.

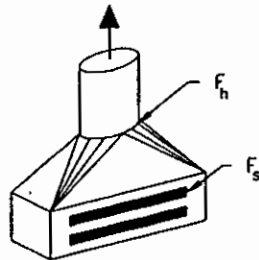

$$h_e = F_s VP_s + F_h VP_d$$

MISCELLANEOUS VALUES

HOOD	ENTRY LOSS COEFFICIENT F_h
Abrasive blast chamber	1.0
Abrasive blast elevator	2.3
Abrasive separator	2.3
Elevators (enclosures)	0.69
Flanged pipe plus close elbow	0.8
Plain pipe plus close elbow	1.60

AMERICAN CONFERENCE
OF GOVERNMENTAL
INDUSTRIAL HYGIENISTS

HOOD ENTRY LOSS COEFFICIENTS

DATE 1-95

FIGURE 5-15

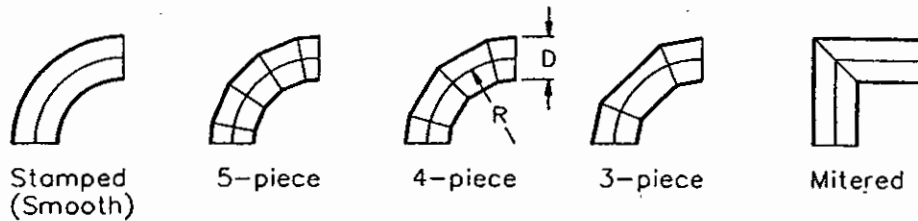

	R/D					
	0.5	0.75	1.00	1.50	2.00	2.50
Stamped	0.71	0.33	0.22	0.15	0.13	0.12
5-piece	-	0.46	0.33	0.24	0.19	0.17*
4-piece	-	0.50	0.37	0.27	0.24	0.23*
3-piece	0.90	0.54	0.42	0.34	0.33	0.33*

* extrapolated from published data

OTHER ELBOW LOSS COEFFICIENTS

- Mitered, no vanes 1.2
- Mitered, turning vanes 0.6
- Flatback (R/D = 2.5) 0.05 (see Figure 5-23)

NOTE: Loss factors are assumed to be for elbows of "zero length." Friction losses should be included to the intersection of centerlines.

ROUND ELBOW LOSS COEFFICIENTS

(Ref. 5.13)

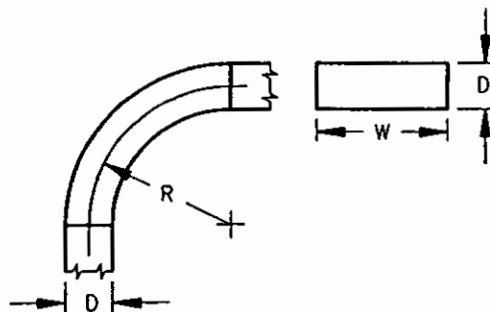

R/D	Aspect Ratio, W/D					
	0.25	0.5	1.0	2.0	3.0	4.0
0.0 (Mitered)	1.50	1.32	1.15	1.04	0.92	0.86
0.5	1.36	1.21	1.05	0.95	0.84	0.79
1.0	0.45	0.28	0.21	0.21	0.20	0.19
1.5	0.28	0.18	0.13	0.13	0.12	0.12
2.0	0.24	0.15	0.11	0.11	0.10	0.10
3.0	0.24	0.15	0.11	0.11	0.10	0.10

SQUARE & RECTANGULAR ELBOW LOSS COEFFICIENTS

AMERICAN CONFERENCE
OF GOVERNMENTAL
INDUSTRIAL HYGIENISTS

DUCT DESIGN DATA
ELBOW LOSSES

DATE 1-95

FIGURE 5-16

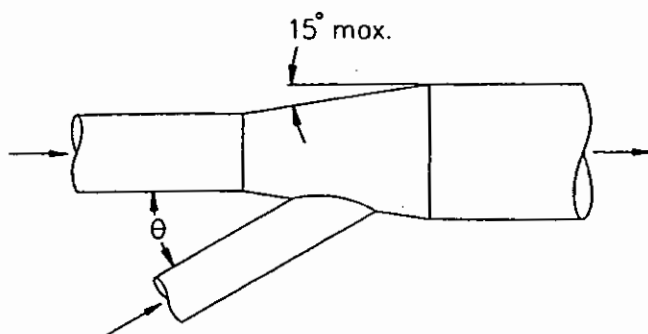

Note: Branch entry loss assumed to occur in branch and is so calculated.

Do not include an enlargement regain calculation for branch entry enlargements.

Angle θ Degrees	Loss Fraction of VP in Branch
10	0.06
15	0.09
20	0.12
25	0.15
30	0.18
35	0.21
40	0.25
45	0.28
50	0.32
60	0.44
90	1.00

BRANCH ENTRY LOSSES

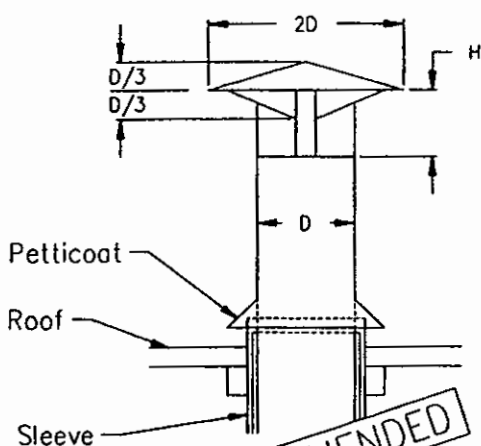

H, No. of Diameters	Loss Fraction of VP
1.0 D	0.10
0.75 D	0.18
0.70 D	0.22
0.65 D	0.30
0.60 D	0.41
0.55 D	0.56
0.50 D	0.73
0.45 D	1.0

WEATHER CAP LOSSES

See Fig. 5-30

AMERICAN CONFERENCE
OF GOVERNMENTAL
INDUSTRIAL HYGIENISTS

DUCT DESIGN DATA

DATE 1-95

FIGURE 5-17

STATIC PRESSURE REGAINS FOR EXPANSIONS

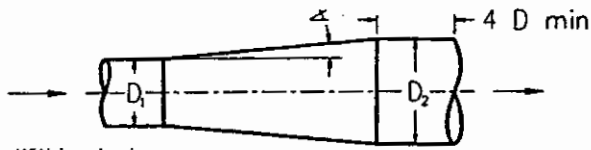

Within duct

Regain (R), fraction of VP difference					
Taper angle degrees	Diameter ratios D_2/D_1				
	1.25:1	1.5:1	1.75:1	2:1	2.5:1
3 1/2	0.92	0.88	0.84	0.81	0.75
5	0.88	0.84	0.80	0.76	0.68
10	0.85	0.76	0.70	0.63	0.53
15	0.83	0.70	0.62	0.55	0.43
20	0.81	0.67	0.57	0.48	0.43
25	0.80	0.65	0.53	0.44	0.28
30	0.79	0.63	0.51	0.41	0.25
Abrupt 90	0.77	0.62	0.50	0.40	0.25

Where: $SP_2 = SP_1 + R(VP_1 - VP_2)$

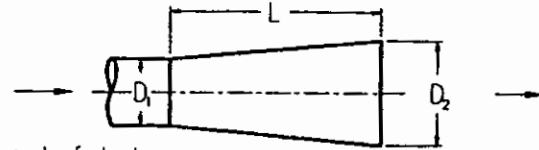

At end of duct

Regain (R), fraction of inlet VP						
Taper length to inlet diam L/D	Diameter ratios D_2/D_1					
	1.2:1	1.3:1	1.4:1	1.5:1	1.6:1	1.7:1
1.0:1	0.37	0.39	0.38	0.35	0.31	0.27
1.5:1	0.39	0.46	0.47	0.46	0.44	0.41
2.0:1	0.42	0.49	0.52	0.52	0.51	0.49
3.0:1	0.44	0.52	0.57	0.59	0.60	0.59
4.0:1	0.45	0.55	0.60	0.63	0.63	0.64
5.0:1	0.47	0.56	0.62	0.65	0.66	0.68
7.5:1	0.48	0.58	0.64	0.68	0.70	0.72

Where: $SP_1 = SP_2 - R(VP_1)$

When $SP_2 = 0$ (atmosphere) SP_1 will be (-)

The regain (R) will only be 70% of value shown above when expansion follows a disturbance or elbow (including a fan) by less than 5 duct diameters.

STATIC PRESSURE LOSSES FOR CONTRACTIONS

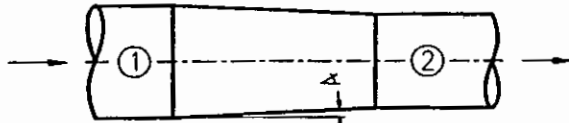

Tapered contraction
 $SP_2 = SP_1 - (VP_2 - VP_1) - L(VP_2 - VP_1)$

Taper angle degrees	L(loss)
5	0.05
10	0.06
15	0.08
20	0.10
25	0.11
30	0.13
45	0.20
60	0.30
over 60	Abrupt contraction

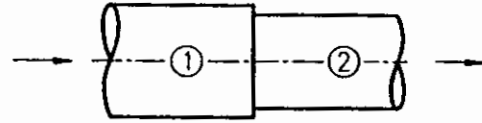

Abrupt contraction
 $SP_2 = SP_1 - (VP_2 - VP_1) - K(VP_2)$

Ratio A_2/A_1	K
0.1	0.48
0.2	0.46
0.3	0.42
0.4	0.37
0.4	0.32
0.6	0.26
0.7	0.20

$A =$ duct area, ft^2

Note:

In calculating SP for expansion or contraction use algebraic signs: VP is (+), and usually SP is (+) in discharge duct from fan, and SP is (-) in inlet duct to fan.

AMERICAN CONFERENCE
OF GOVERNMENTAL
INDUSTRIAL HYGIENISTS

DUCT DESIGN DATA

DATE 1-95 FIGURE 5-18